

Telstra CR2000

Cordless Rental Telephone User Guide

This telephone has been designed for ease of use. Please read the instructions in (*Setting up the Telstra CR2000*) and keep it handy for future reference.

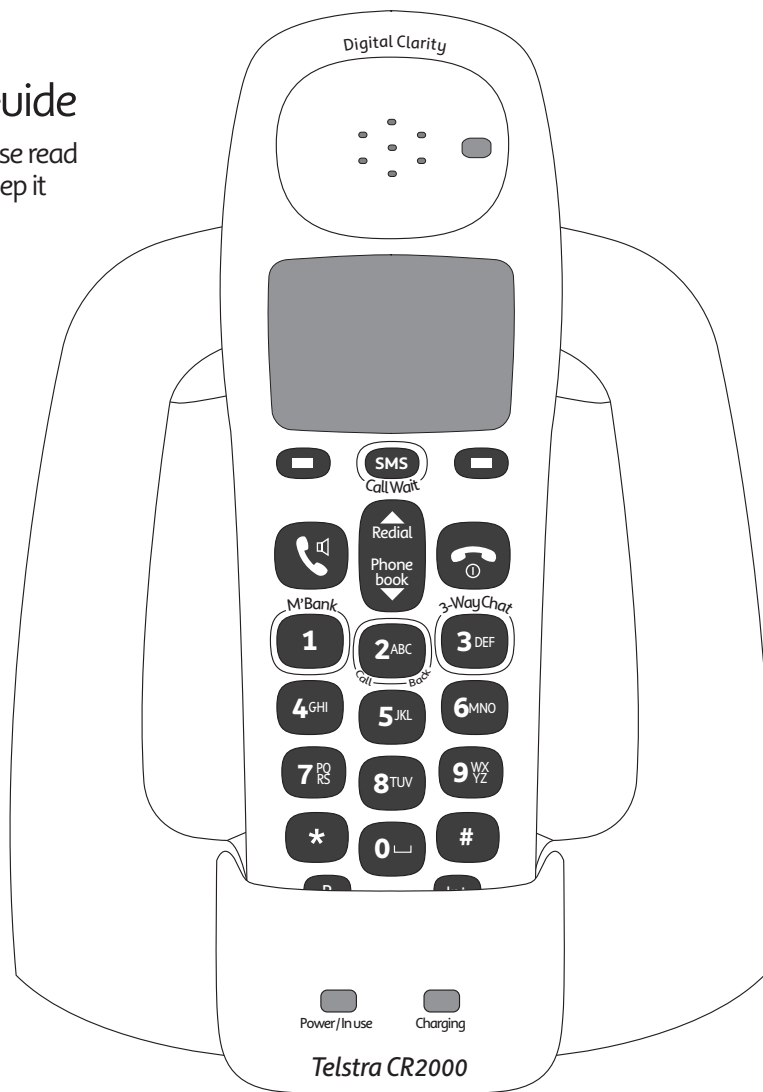

If you have any problems with your phone, refer to the Troubleshooting section of this User Guide.



In this guide

Telstra CR2000 parts checklist	4	Handset Settings	20
Setting up your Telstra CR2000	5	Ringtone	20
Connecting the base station	5	To set Ringtone	20
Install battery	5	Ringer Volume	20
Charge battery	6	To set Ringer Volume	20
Battery life and range	6	Receiver call volume	21
Talk time and stand-by	6	To set Receiver call volume	21
Low battery warning	7	Handset name	21
Out of range warning	7	To set Handset name	21
Wall mounting your Telstra CR2000	8	Wallpaper	22
Getting to know your Telstra CR2000	10	To set Wallpaper	22
Display icons & symbols	11	Menu colour	22
CR2000 Base Station	12	Screensaver	22
Main features of your CR2000	12	To set Screensaver	22
Menu navigation	13	Light Timeout	23
Stand-by mode	14	To set Light Timeout	23
Text and number entry	14	Display Contrast	23
Symbol panel	15	To set Display Contrast	23
Emoticons	15	Auto Talk	24
Default settings	15	To set Auto Talk	24
Using the CR2000	16	Key Beeps	24
Make a call	16	To set Key Beeps	24
Pre-dial	16	Redial Length	25
Call from the Phonebook	16	To set Redial Length	25
Search alphabetically for Phonebook entries.	16	Base Settings	25
Call from the call lists	16	Ringtone	25
Answer a call with handset on the base station	16	To set Ringtone	25
Answer a call with handset off the base station	17	Base Ringer Volume	25
Silence	17	To set Base Ringer Volume	25
Answer a call in handsfree mode	17	Ring Priority	26
Adjust loudspeaker volume	17	To set Ring Priority	26
End a call	17	First Ring	26
Call in progress	17	To set First Ring	26
Adjust earpiece volume	17	Master Reset	27
Mute	17	To achieve a master reset	27
Loudspeaker mode	18	Lock keypad	27
Intercom	18	Paging	27
Call another handset	18	Switch on/off handset	27
Transfer an external call to another handset	18	Phonebook	28
Switch between an internal and external call	18	Access the names list	28
Three-party conference call	19	Add entry in the Phonebook	28
Clock & Alarm	19	View the Phonebook	28
Set date and time	19	Edit Phonebook entry	29
Set Alarm On	19	Delete Phonebook entry	29
Switch alarm off	20	Delete all Phonebook entries	29
Set time format	20	Copy entry to another handset	29
		Copy Phonebook from SIM	30
		Copy entry to SIM	31
		Copy Phonebook to another handset	31

In this guide

Copy Phonebook to SIM	31
Dialling code	32
Check Phonebook capacity	32
Reminders	32

Telstra network services 33

Messagebank®	33
To retrieve a message from your message service	33
Flashing Message Indication (FMI)	33
Call Back	33
How do I use Call Back?	33
To cancel a Call Back	33
To find out if you have a Call Back arranged	33
3-Way Chat	34
How to use 3-Way Chat	34
To split a 3-Way Chat or switch between callers	34
Other Phone Features	34
View and dial a Phone Feature	34
Call Waiting	34
Calling Number Display	35
Calls Lists	35
Access the calls lists	35
Save number from the Calls List to the Phonebook	35
Delete a Calls List entry	36
Delete all entries in a Calls List	36
Access the redial list	36
Save redial list entry to Phonebook	36
Delete number from redial list	36

Text Messaging (SMS) 37

Write and send new text messages	38
Key operation	38
Send a message to a number in a calls list	38
Save a message	39
Insert a symbol	39
Insert Emoticon	39
Insert Template	39
Edit Template	40
Delete Template	40
Send text message to previously dialled number	40
Inbox	40
View messages in the main Inbox	41
View messages in an individual mailbox	41
To set an individual user mailbox	41
Reply to an Inbox message	42
Forward an Inbox message	42
View message details	42
Call a sender's number	42
Save a sender's number	42
Delete an Inbox message	42

Draft Box	43
Review or Edit Draft messages	43
Edit a message in Draft Box	43
Send a message from Draft Box	43
Outbox	44
View a message in the Outbox	44
Forward a message from the Outbox	44
Delete messages from the Outbox	45
Delete messages	45
Delete all messages	45
Text Message settings	46
Mailboxes	46
Add user mailboxes	46
Receive a message to a mailbox	46
View messages in a mailbox	47
Edit a user mailbox	47
Delete a user from a mailbox	47
Set message size	48
Message Alert	48
Service Centres	48
To set outgoing number	49
To set incoming number	49
Set default Text Message send centre	49

Register an additional handset 50

Register an additional handset	50
To register an additional handset	50
Switch bases	50
To switch bases	50
De-register a handset	50
To De-register a handset	50

Troubleshooting 52

General Information 54

Replacing the handset batteries	54
Safety	54
General	54
Cleaning	55
Environmental	55
How many telephones can you have?	55

Product Service, Terms and Conditions 56

Rental terms and conditions	56
Rental telephone faults	56
Things you need to know	56

Telstra CR2000 parts checklist

If anything is missing, please contact Telstra on 13 2200.



CR2000 Handset



CR2000 Base

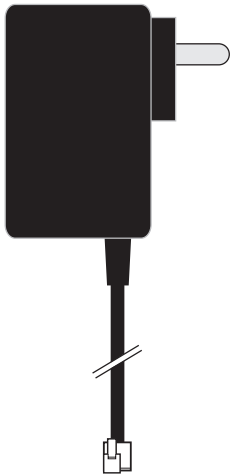

AC Power Adaptor



Telephone line cords (long line cord for standard installation, short line cord for wall mounting)

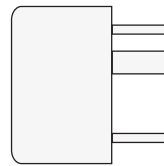

Phone adaptor plug



NiMH batteries x 2

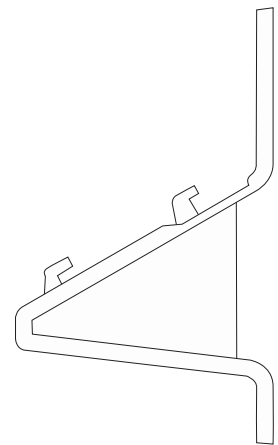

CR2000 Wall mounting bracket

Setting up your Telstra CR2000

Connecting the base station

1. Place the base station within reach of the telephone line and electrical power sockets.
2. Plug the line cord and the power cable to the sockets at the back of the base station as shown (A), and secure cords in the cable clamps provided in the base.

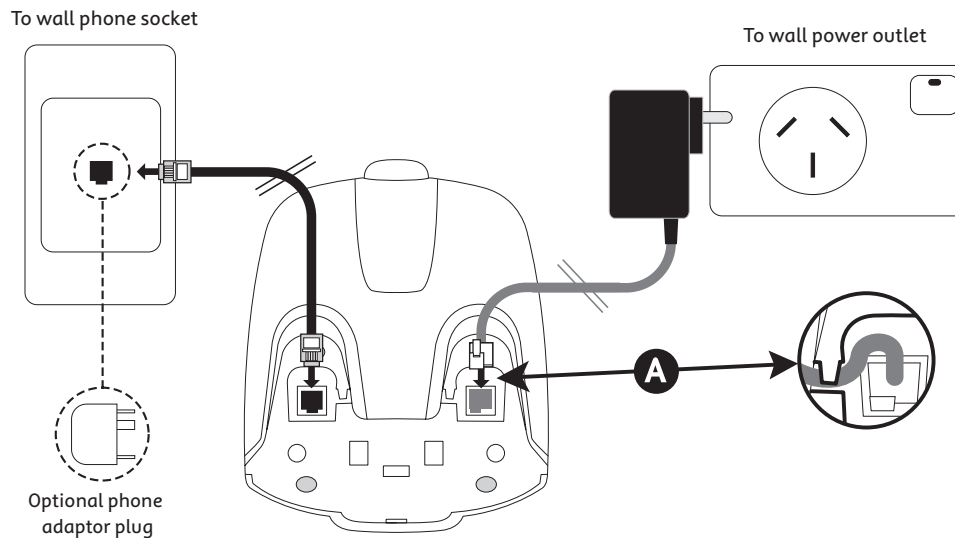

3. Plug the other end of the line cord and power cable in to the telephone wall socket and mains power socket.

Connect the line cord to the line adaptor before plugging it into the line socket if required.

TIP: The position of the base station can affect the range and performance of your CR2000. Avoid placing the base station too close to large metal objects such as filing cabinets, radiators or electrical appliances. This can impair the range and sound quality. Buildings with thick internal and external walls may impair transmission of signals to and from the base.

WARNING: The base station does not have an ON/OFF switch. Power is applied when the power adaptor is plugged into the unit and connected to the electricity socket. The only way to power down the unit is to unplug the power adaptor from the electrical power socket. Therefore, ensure that the electrical power socket is easily accessible.

Install battery

Your CR2000 is supplied with 2 rechargeable batteries. Before using the handset, the batteries must be installed and charged for at least 24 hours.

1. Slide out the battery cover.
2. Insert the batteries as shown and replace the cover.

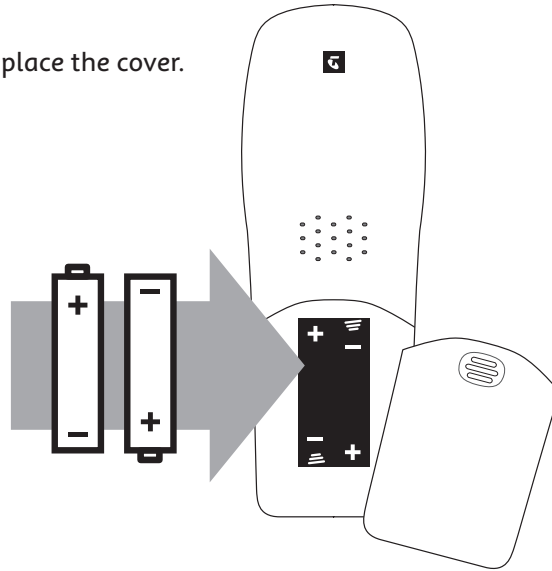

Charge battery

1. Place the handset on the charging cradle of the base station. A beep confirms that the handset is placed correctly.
2. A charging animation on the handset screen shows that the battery is charging.



3. The handset is fully charged when the charging animation stops and  is displayed.

Battery life and range

Talk time and stand-by

When the battery is fully charged, the talk time of your CR2000 is approximately 12 hours and the stand-by time is approximately 150 hours.

Low battery warning

The battery level is shown at the top right of the handset screen. When the battery level becomes low, you hear a beep and the battery icon flashes.

A low battery alert will inform you that the handset has to be recharged. If this happens during a call, the call may end shortly after the alert.

If the battery level is very low, the phone automatically switches off shortly after the alert. Any function in progress will not be saved.

The approximate power levels of your battery are indicated as follows:

 Battery is fully charged

 Battery is partially charged

 Battery is running low

 Battery is almost empty

Out of range warning

If the handset moves out of range, the antenna icon  will flash.

If out of range, the screen shows `Searching...` then shows `Not Available`. Move back in range to make and receive calls and text messages again.

The effective range of the phone can be affected by environmental factors such as proximity to power lines

TIP Avoid placing the base station too close to large metal objects such as filing cabinets, radiators or electrical appliances.

This can impair the range and sound quality. Buildings with thick internal and external walls may impair transmission of signals to and from the base.

Wall mounting your Telstra CR2000

The Telstra CR2000 can be wall mounted to a standard Telstra wall mount plate. To wall mount the Telstra CR2000 proceed as follows:

1. Place the wall mount bracket over the two retaining screws of your standard Telstra wall mount plate.
2. Slide the bracket downward into position.

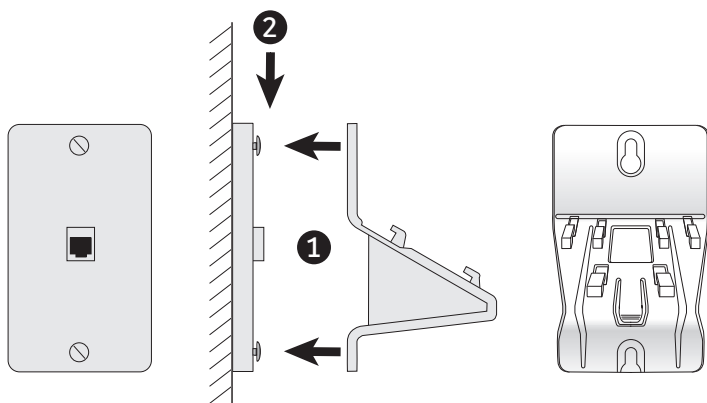

3. Insert the short line cord into the telephone socket wall plate and the other end to the line socket of the telephone. Secure the line cord under the clamp of the telephone as shown in the circle inset.

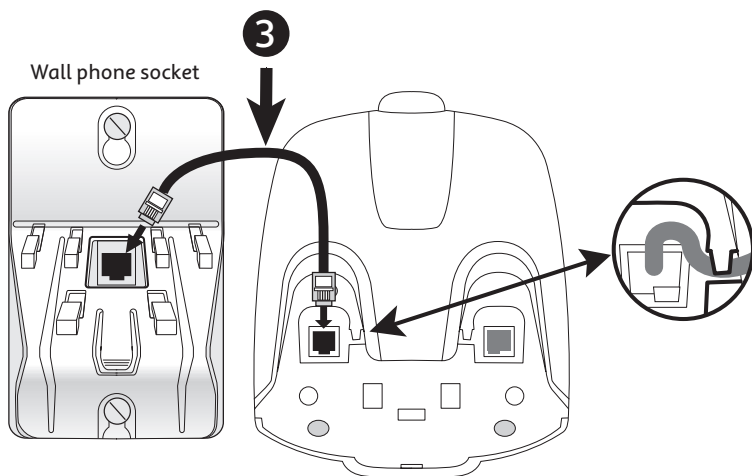

4. Thread the power cord from the power supply through the side of the wall bracket and through the centre of the bracket. Plug the power cord into the power socket of the telephone. Secure the power cord under the clamp of the telephone as shown in the circle inset.

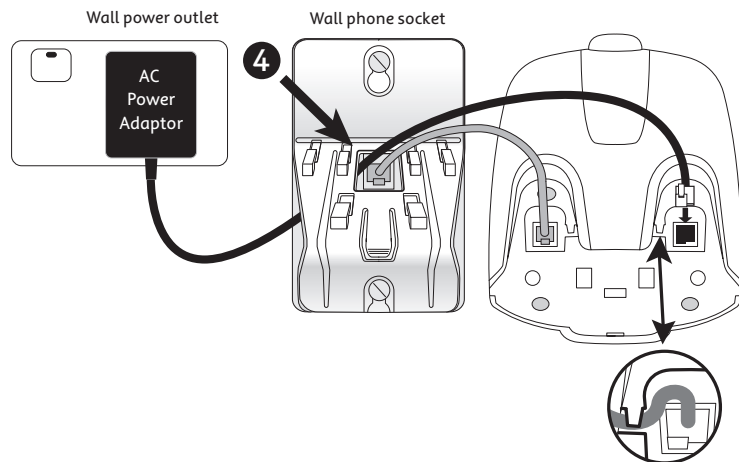

5. Align the holes on the bottom of the telephone base with the lugs on the wall bracket. Slide the telephone base downward on the bracket until you hear it click into place.

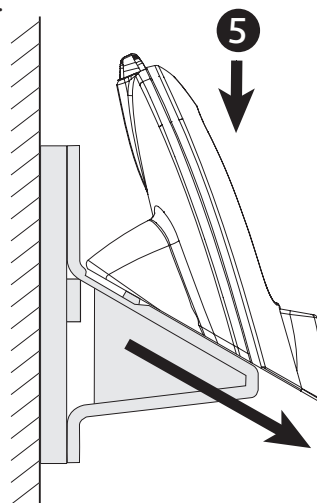

To remove the CR2000 from the wall mounting bracket

6. Gently press the release tab and slide the CR2000 base up and back to remove the base from the bracket.

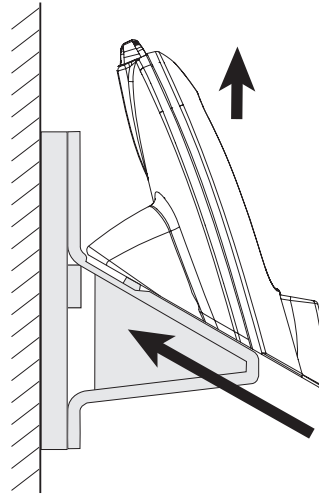
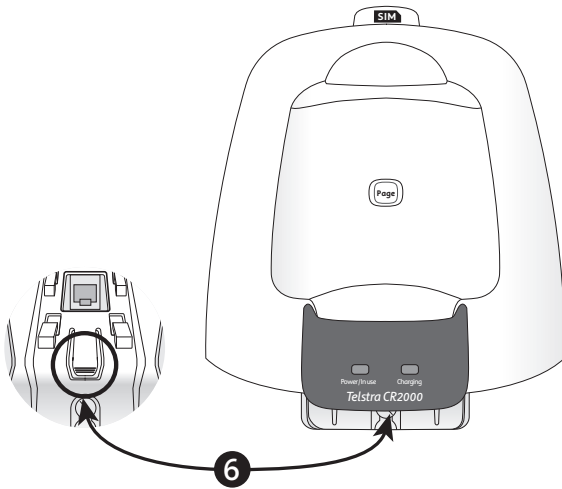

7. Disconnect the power and line cords.

Getting to know your Telstra CR2000



CR2000 Handset

1. Indicator light

ON - Handset in use
Flashing - Handset ringing
Flashing - Missed calls or text messages¹

2. Display screen

Go to the Redial list from standby mode. Increase the earpiece volume during a call.

Long press - enter a Pause when dialling or storing a number.

Scroll through options from on-screen menus.

3. Up/Redial key

Enter the Names list from standby mode.

Decrease the earpiece Volume during a call.

Scroll through options from on-screen menus.

4. Down/Phonebook key

Enter the main menu from standby mode. Select the function displayed on the handset screen directly above it

5. Left Soft key

Enter the text messaging menu from standby and answers Call Waiting² when on a call

6. SMS/Call Wait key

Enter the Phonebook menu. Or to return to previous menu level

7. Right Soft key

Answer an incoming call. Switch between normal and Handsfree mode during a call.

8. Talk/Handsfree key

Hang up a call. When in a menu, returns you to the previous menu level or standby.

Long press - in standby mode turns handset ON or OFF

9. End/Power key

For internal calls or call transfers between handsets.

10. Alphanumeric keypad

To access dial tone during a call

11. Intercom key

Long press - dials MessageBank^{®3} or Telstra Telstra Home Messages 101^{®4}.

12. Microphone









Long press - sets up a Call Back⁵ to a busy number.

13. Recall key

Long press - sets up a 3-Way Chat⁵ after answering a Call Wait.

Display icons & symbols

In stand-by mode, several icons & symbols may be displayed on the handset.

-  The handset is registered and within range of the base station. It blinks when the handset is out of range or is searching for a base
-  Battery symbol indicating 4 different battery levels
-  The ringer volume is set to zero
-  The Handsfree loudspeaker is on
-  There is a missed call or missed calls are being reviewed
-  There are text messages
-  There are Voicemail messages on Telstra MessageBank^{®3} or Telstra Home Messages 101^{®4}
-  Alarm clock is activated
-  The keypad is locked

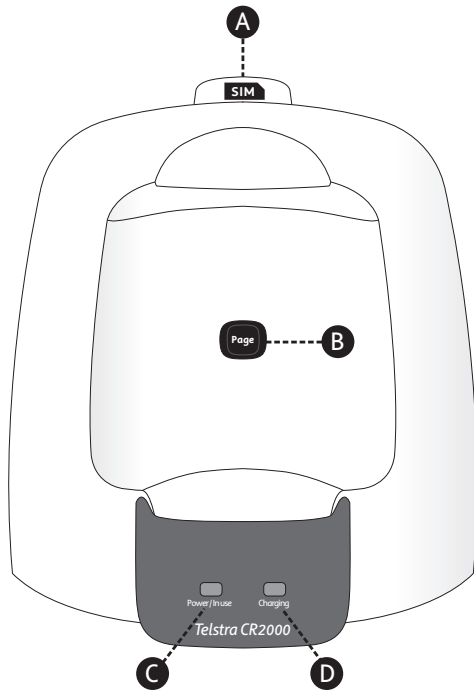

CR2000 Base Station

- A. SIM Card tray
- B. Paging key
- C. Power/In Use Light/New Event
- D. Charging Light





Main features of your CR2000

Here is a quick view of the menu options available in your CR2000. For a full explanation of each menu option, see the detailed sections in this User Guide.

Menu	To	
Text Messaging	Setup, write/read SMS text messages.	Page 37
Calls Lists	Display details of Missed, Received, Dialed Calls. Call, save or delete numbers.	Page 34
Reminders	Add reminders for important dates or events and get an alert of the event.	
Phone Features	Access special Telstra phone services.	Page 34
Clock & Alarm	Set Date and Time, Alarm and Alarm tone.	Page 19
Settings	Set display on handset and Ringtone, Ringer Volume, Receiver Volume, and more on handset and base.	
Registration	Register and De-register handsets. Select preferred base.	Page 50

Menu navigation

The basic steps of navigating through the menus and on-screen options.



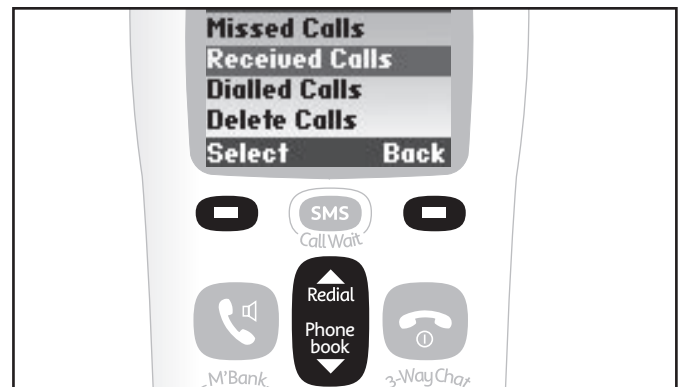
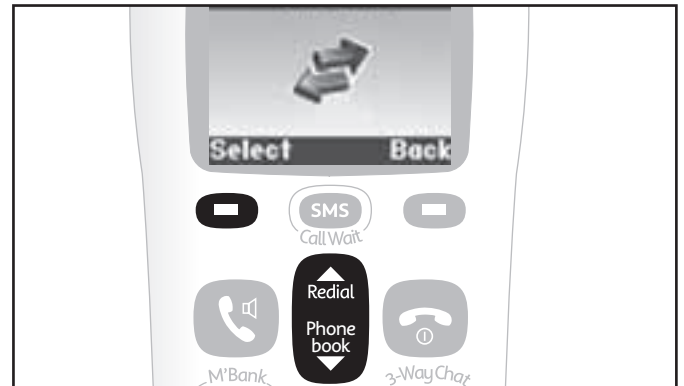









Task	To
Open main menu	Press MENU
Go to a specific menu option	1 Press  or  key to scroll to the menu/option you want.
Confirm your selection	2. SELECT the option by pressing the left soft key.
To change your selection	1 Press  or  to scroll to the option you want
To confirm your selection	2. SELECT the option by pressing the left soft key.
Return to previous menu or stand-by screen	3 Go BACK by pressing the right soft key.



Stand-by mode

If you do not press any button for 30 seconds the handset will automatically return to stand-by mode.

Text and number entry

Button	Upper case	Lower case
	. , - ? ! i j ' @ : ; / 1	. , - ? ! i j ' @ : ; / 1
	A B C 2 Ä Æ Å Ç	a b c 2 ä æ å à ç
	D E F 3 É	d e f 3 è é
	G H I 4	g h i 4 i
	J K L 5	j k l 5
	M N O 6 ö ø ò ñ	m n o 6 ö ø ò ñ
	P Q R S 7	p q r s 7 ß
	T U V 8 Ü	t u v 8 ú ü
	W X Y Z 9	w x y z 9
	Space 0	Space 0
	Brings up symbol table in text messaging mode.	
	Short press to switch between Abc, abc and 123 mode.	

For example, to enter the name "Telstra":

1. Press 8 once: T
2. Press 3 twice: Te
3. Press 5 three times: Tel
4. Press 7 four times: Tels
5. Press 8 once: Telst
6. Press 7 three times: Telstr
7. Press 2 once: Telstra

By default, the first letter of a word is in upper case. Press  to switch between upper and lower case.

Symbol panel

.	,	-	?	!	i	¿	'	@	:	;
/	"	()	-	+	&	%	*	=	<
>	£	€	\$	¥	€	\	~	#	§	△
⊕	Γ	Λ	Ω	Π	Ψ	Σ	⊖	≡		

Emoticons



Default settings

Ringer Volume	Volume 3
Earpiece Volume	Volume 3
Speaker Volume	Volume 3
Key Beep	On
Auto Talk	On
Alarm clock	Off

Using the CR2000





Make a call

1. Press  display shows **Callina**. Listen for dial tone.
2. Enter the number to dial.

Pre-dial

1. Enter the phone number, maximum 32 digits. If you make a mistake, press **CLEAR** to delete the last digit.
2. Press  to dial the number.







Call from the Phonebook

1. Press  in stand-by mode.
2. Scroll  or  to a Phonebook entry.
3. Press  to dial the number.

Search alphabetically for Phonebook entries.

1. Press **NAMES** then press **SELECT** to choose **Search**.
2. Press the numeric key containing the first letter of the name you want. For example, pressing 2 will show the entries starting with A. Pressing 2 again will show the entries starting with B, etc...

Call from the call lists

1. Press **MENU** and scroll  or  to **Calls Lists**.
2. Press **SELECT** and scroll  or  to the Calls List you want.
3. Press **SELECT** and scroll  or  to an entry.
4. Press  to dial the number.

You need to subscribe to Telstra Calling Number Display⁷ service to be able to see the caller's number or name in the Missed and Received Calls logs. See page 35 for more details.

Answer a call with handset on base station

Auto Talk mode is On when you receive your CR2000. You can simply lift the handset from the base station to answer a call.

Answer a call with handset off the base station

1. When the phone rings, press  to answer call.

An incoming call has priority over other events. Whenever there is an incoming call, other actions in progress such as phone setting, menu navigation, etc. will be aborted.

TIP If you wish to switch Auto Talk mode to Off, see page 24. The default setting is On



Silence

When an incoming call is received you have the option to ignore the call and silence the ring on a particular handset by pressing the **SILENCE** button.

Should you then choose to accept the call you can do so from the silenced or any other registered handset by pressing .



Note: The base and all other registered additional handsets will continue to ring after **SILENCE** has been pressed.

Answer a call in handsfree mode

1. When the phone rings, press  then press  again. The call is transferred to the handset loudspeaker.
2. Press  to switch between the earpiece and loudspeaker.

WARNING Switching on handsfree mode can suddenly increase the volume in the earpiece to a very high level. Make sure the handset is not too close to your ear.

Adjust loudspeaker volume

1. Press  or  to adjust the volume displayed on-screen.

End a call

1. Press .



The call duration will be displayed on the handset screen for about 2 seconds.

If Auto Talk mode (see page 24) is activated, you can simply place the handset back to its base station to end the call. This feature is activated by default.

Call in progress

The following options are available during a call:

Adjust earpiece volume

1. Press  or  to adjust the volume displayed on-screen.

Mute

You can mute the microphone so that you can talk to someone else in the room without your caller hearing you.

1. Press **MUTE** to turn the microphone off.
2. Press **OFF** to cancel the mute function and turn on the microphone.

Intercom

This feature is only available when there are at least 2 registered handsets. It allows you to make internal calls, transfer external calls from one handset to another and use the conference option.

Call another handset

1. Press **Int**.
2. Press the number of the other handset then **OK**
3. Press  to end the call.

If the additional handset is not a CR2000e Telstra CR2000e extension handset, this function may not be available.
For information on how to obtain a CR2000e Extension handset please contact Telstra on 13 2200.

Transfer an external call to another handset

1. During an external call, press **Int**. Your caller is put on hold.
2. Enter the number of the other handset and press **OK**.
3. When the other handset answers you can announce the caller.
4. When the other handset answers the internal call; Either press **END** to transfer the call OR press  on the other handset to return to the external caller. If the other handset does not answer, press **Int** to speak to your caller again.

Switch between an internal and external call



1. During an external call, press **Int**. Your caller is put on hold.
2. Enter the number of the other handset and press **OK**.
3. When the other handset answers you can speak privately to your internal caller.
4. Press  to hang up.

Three-party conference call

1. During an external call, press **Int**. Your caller is put on hold.
2. Enter the number of the other handset and press **OK**.
3. When the other handset answers, press **JOIN** to join both calls together. The display shows **Conference Call**.
4. Press  to hang up.







Clock & Alarm

Set date and time

1. Press **MENU**, scroll  or  to **Clock & Alarm** and press **SELECT**.
2. Press **SELECT** to choose **Date & Time**
3. Press **SELECT** again and enter the date DD/MM/YY then time HH:MM
4. Press **SAVE** then **BACK** to return to menu or press  to return to stand-by.

Enter the date in Day/Month/Year format and the time in 24-hour format.

Set Alarm On

1. Press **MENU**, scroll  or  to **Clock & Alarm** and press **SELECT**.
2. Scroll  to **Alarm** and press **SELECT**.
3. Scroll  or  to **On** and press **SELECT**.
4. Scroll  or  to choose:

Once for a once only alarm

Mon-Fri for alarm to sound Monday-Friday only

On Daily for the alarm to sound every day

5. Press **SELECT**, enter the time for the alarm to go off and press **SAVE**.
6. Press **BACK** to return to menu or press  to return to stand-by.

When the alarm is set On the  BELL ICON is displayed.



Switch alarm off

1. When the alarm goes off, press **STOP**.



If no button is pressed the alarm will stop automatically after one minute.

Set time format

Choose between 12/24 hour formats.

1. Press **MENU**, scroll  or  to **Clock & Alarm** and press **SELECT**.

2. Scroll  to **Time Format** and press **SELECT**.

3. Scroll  or  to **12 hour or 24 hour** and press **SELECT**.

4. Press **BACK** to return to menu or press  to return to stand-by.

Handset settings

Ringtone

Choose from 10 ringtones. You can set different ringtones for internal and external calls.

To set Ringtone

1. Press **MENU** then scroll  or  to **Settings** and press **SELECT**.

2. Press **SELECT** to choose **Handset Settings**.

3. Press **SELECT** again and scroll  or  to choose **External or Internal Calls**.

4. Press **SELECT** and scroll  or  to choose the ringtone.

5. Press **SELECT** to confirm.

6. Press **BACK** to return to menu or press  to return to stand-by.

Ringer Volume



There are 5 volume levels.

To set Ringer Volume

1. Press **MENU** then scroll  or  to **Settings** and press **SELECT**.

2. Press **SELECT** to choose **Handset Settings**.

3. Press **SELECT** again and scroll  or  to **Ringer Volume**, and press **SELECT**.

4. Scroll  or  to choose Volume 1-5 or Ringer Off.
5. Press **SELECT** to confirm.
6. Press **BACK** to return to menu or press  to return to stand-by.







When Ringer Off is selected, the  icon is displayed on the screen.

WARNING When the handset rings during an incoming call, please do not hold the handset too close to your ear as the volume of the ringing tone may damage your hearing.

Receiver call volume

There are 8 volume levels





To set Receiver call volume

1. Press **MENU** then scroll  or  to Settings and press **SELECT**.
2. Press **SELECT** to choose Handset Settings.
3. Scroll  or  to Receiver Volume.
4. Press **SELECT** and scroll  or  to choose the Volume 1-8
5. Press **SELECT** to confirm.
6. Press **BACK** to return to menu or press  to return to stand-by.

Handset name

You can name the handset and display the handset name in stand-by mode. The default handset name of your handset is TELSTRA. The handset name can be a maximum of 10 characters, e.g. Mike, Kitchen.







To set Handset name

1. Press **MENU** then scroll  or  to Settings and press **SELECT**.
2. Press **SELECT** to choose Handset Settings.
3. Scroll  to Handset Name.
4. Press **SELECT** and enter the name.
5. Press **SAVE** to confirm.
6. Press **BACK** to return to menu or press  to return to stand-by.







Wallpaper

Your CR2000 can display 3 different wallpapers.

To set Wallpaper

1. Press **MENU** then scroll  or  to **Settings** and press **SELECT**.
2. Press **SELECT** to choose **Handset Settings**.
3. Scroll  to **Wallpaper**.
4. Press **SELECT** and scroll  or  to choose the wallpaper.
5. Press **SELECT** to see the wallpaper
6. Press **USE** to select the wallpaper.
7. Press **BACK** to return to menu or press  to return to stand-by.







Menu colour

1. Press **MENU** then scroll  or  to **Settings** and press **SELECT**.
2. Press **SELECT** to choose **Handset Settings**.
3. Scroll  to **Menu Colour**.
4. Press **SELECT** and scroll  or  to choose the colour **Blue**, **Orange** or **Pink**.
5. Press **SELECT** to use the colour.
7. Press **BACK** to return to menu or press  to return to stand-by.

Screensaver

The screensaver displays a clock face plus the time and date. The screensaver comes on when the backlight goes off and will only appear when your handset is in stand-by.

To set Screensaver







1. Press **MENU** then scroll  or  to **Settings** and press **SELECT**.
2. Press **SELECT** to choose **Handset Settings**.
3. Scroll  or  to **Screensaver**.
4. Press **SELECT** and scroll  or  to **Clock** or **Off**.
5. Press **SELECT** to confirm.
6. Press **BACK** to return to menu or press  to return to stand-by.

Light Timeout

You can set how long the backlight stays on – 15, 30 or 45 seconds.

Note: The default setting is 30 seconds







To set Light Timeout

1. Press **MENU** then scroll  or  to **Settings** and press **SELECT**.
2. Press **SELECT** to choose **Handset Settings**.
3. Scroll  or  to **Light Timeout**.
4. Press **SELECT** and scroll  or  to **15, 30 or 45 seconds**.
5. Press **SELECT** to confirm.
6. Press **BACK** to return to menu or press  to return to stand-by.



Display Contrast

You can adjust the contrast to suit different lighting conditions.







To set Display Contrast

1. Press **MENU** then scroll  or  to **Settings** and press **SELECT**.
2. Press **SELECT** to choose **Handset Settings**.
3. Scroll  or  to **Display Contrast**.
4. Press **SELECT** and scroll  or  to **Low, Medium or High**.
5. Press **SELECT** to confirm.
6. Press **BACK** to return to menu or press  to return to stand-by.

Auto Talk

This function enables you to answer a call automatically by simply lifting the handset from the base station or charger and ending a call by returning it to the base station or charger. The default setting is On. When Auto Talk is switched off, you must always press  to answer a call and  to end a call.







To set Auto Talk

1. Press **MENU** then scroll  or  to **Settings** and press **SELECT**.
2. Press **SELECT** to choose **Handset Settings**.
3. Scroll  or  to **Auto Talk**.
4. Press **SELECT** and scroll  or  to **On** or **Off**.
5. Press **SELECT** to confirm.
6. Press **BACK** to return to menu or press  to return to stand-by.

Key Beeps

A single beep is emitted when a key is pressed. You can enable or disable this key beep. By default, key beep is On.







To set Key Beeps

1. Press **MENU** then scroll  or  to **Settings** and press **SELECT**.
2. Press **SELECT** to choose **Handset Settings**.
3. Scroll  or  to **Key Beep**.
4. Press **SELECT** and scroll  or  to **On** or **Off**.
5. Press **SELECT** to confirm.
6. Press **BACK** to return to menu or press  to return to stand-by.

Redial Length

This adjusts the number of digits dialled when using the redial list of the CR2000 (see page 36).

To set Redial Length

1. Press **MENU** then scroll  or  to **Settings** and press **SELECT**.
2. Press **SELECT** to choose **Handset Settings**.
3. Scroll  or  to **Redial Length**.
4. Press **SELECT** and scroll  or  to **Long (32 Digits)** or **Short (20 Digits)**.
5. Press **SELECT** to confirm.
6. Press **BACK** to return to menu or press  to return to stand-by.





Note: Selecting Short limits the number of digits stored in the redial memory to the first 20 dialled. This can be a useful security feature if you are using telephone banking and wish to limit the amount of information stored.

Base Settings

Ringtone

Choose from 5 polyphonic ringtones







To set Ringtone

1. Press **MENU** then scroll  or  to **Settings** and press **SELECT**.
2. Scroll **DOWN** to **Base Settings** and press **SELECT**.
3. Scroll  or  to choose the ringtone.
4. Press **SELECT** to confirm.
5. Press **BACK** to return to menu or press  to return to stand-by.

Base Ringer Volume

There are 5 volume levels











To set Base Ringer Volume

1. Press **MENU** then scroll  or  to **Settings** and press **SELECT**.
2. Scroll **DOWN** to **Base Settings** and press **SELECT**.
3. Scroll  or  to **Ringer Volume**.
4. Press **SELECT** and scroll  or  to choose the **Volume 1-5** or **Ringer Off**.
5. Press **SELECT** to confirm.
6. Press **BACK** to return to menu or press  to return to stand-by.

Ring Priority

If you have more than one handset, all handsets normally ring at the same time. You can set one handset to ring 2, 4 or 6 rings before the others. This gives one person the chance to act as a receptionist and answer incoming calls first. Calls can then be transferred to other handsets see page 18.







To set Ring Priority

1. Press **MENU** then scroll  or  to **Settings** and press **SELECT**.
2. Scroll **DOWN** to **Base Settings** and press **SELECT**.
3. Scroll  or  to **Ring Priority**.
4. Press **SELECT** and scroll  or  to **All Handsets** or **Select Handset**.
5. Press **SELECT**. If you chose **Select Handsets**, scroll  or  to the handset number you want to ring first. Press **SELECT** to confirm. Then press  or  to set the number of rings that will be heard before the other handsets start ringing.
6. Press **BACK** to return to menu or press  to return to stand-by.

First Ring

When this function is set to On the first ring burst from a voice call or a text message will always sound as the standard ring. If you want to mute the first ring burst for text messages and ensure that distinctive rings matched to names in the Phonebook always sound first, this function should be set to Off. See page 28 for information on how to set ringtones to match names.





To set First Ring

1. Press **MENU** then scroll  or  to **Settings** and press **SELECT**.
2. Scroll **DOWN** to **Base Settings** and press **SELECT**.
3. Scroll  or  to **First Ring**.
4. Press **SELECT** and scroll  or  to choose **On** or **Off**.
5. Press **SELECT** to confirm.
6. Press **BACK** to return to menu or press  to return to stand-by.

Master Reset





This restores all the original settings to your CR2000. However, entries stored in the Phonebook and handset registrations will not be affected.

To achieve a master reset

1. Press **MENU** then scroll  or  to **Settings** and press **SELECT**.
2. Scroll **DOWN** to **Base Settings** and press **SELECT**.
3. Scroll  or  to **Master Reset**.
4. Press **SELECT** then press **YES** to confirm or **NO** to cancel.
5. If **YES** enter your System PIN default setting **0000**.
6. Press **OK** and wait while your CR2000 is reset.



Lock keypad

Lock the keypad to prevent accidental dialling while carrying the handset around.

1. Press *and hold* . An icon confirms the keypad is locked and the screen shows .
2. To unlock the keypad, press **UNLOCK** then . The  key must be pressed within 2 seconds.

Paging

Paging is a useful way of finding lost handsets.

1. Press  on the base. All handsets ring and display **Paging Call**.
2. Press **CANCEL** the paging call on the handset, or press  again on the base.

Switch on/off the handset





1. When the handset is in standby, press *and hold*  to switch the handset off. To switch the handset on press the .

Phonebook





Your CR2000 can store up to 255 Phonebook entries. Each entry can hold up to 24 digits for the phone number and 12 characters for the name.

Access the Names list

1. Press  in standby mode or press **NAMES**





TIP: Instead of scrolling  or  to browse the Phonebook entries, you can press the numeric key corresponding to the first letter of the entry you wish to locate. For example, pressing  key will show the entries starting with A. Pressing  again will show the entries starting with B, etc...

Add entry in the Phonebook





1. Press **NAMES**
2. Scroll  to **Add Entry** and press **SELECT**
3. Enter the name maximum 12 characters. Press **SAVE**.
4. Enter the number maximum 24 digits. Press **SAVE**.
5. Scroll  or  to select the ringer melody. Press **SELECT**. The display shows **Name Saved**.
6. Press **BACK** to return to menu or press  to return to stand-by.



When entering a name, the first character is automatically given as an upper case letter with the rest of the name in lower case lettering. You can change the case from lower case to upper case or numbers using the  key

View the Phonebook







1. Press  in standby mode or press **NAMES** then **SELECT** to search the list.
2. The entries are listed in alphabetical order.
3. Scroll  or  browse the Phonebook.
4. To view details of a Phonebook entry, press **OPTIONS** then **SELECT** to show the details.
5. Press **BACK** to return to menu or press  to return to stand-by.

Edit Phonebook entry



1. Press  in stand-by mode.
2. Scroll  or  to the entry and press **OPTIONS**.
3. Scroll  or  to **Edit Entry** and press **SELECT**. Press **CLEAR** to delete current name. Enter the new name then press **OK**.

4. Press **CLEAR** to delete current number. Enter the new number then press **SAVE**.
5. Scroll  or  to select the ringer melody. Press **SELECT**. The display shows Name Saved.
6. Press **BACK** to return to menu or press  to return to stand-by.









Delete Phonebook entry

1. Press  in standby mode.
2. Scroll  or  to the entry and press **OPTION**.
3. Scroll  or  to Delete Entry and press **SELECT**.
4. Screen shows Delete Entry? Press **YES** to confirm or **NO** to cancel.
5. Press **BACK** to return to menu or press  to return to stand-by.

Delete all Phonebook entries

1. Press **NAMES**.
2. Scroll  or  to Delete Phonebook and press **SELECT**.
3. Screen shows Delete All? Press **YES** to confirm or **NO** to cancel.
4. Press **BACK** to return to menu or press  to return to stand-by.

Copy entry to another handset

1. Press  in stand-by mode.
2. Scroll  or  to the entry and press **OPTIONS**.
3. Scroll  or  to Copy Entry and press **SELECT**.
4. To Handset is highlighted. Press **SELECT** then scroll  or  to the destination handset number. Press **SELECT**. The entry is copied.
5. Press **BACK** to return to menu or press  to return to stand-by.

At the receiving handset:

1. The display shows Replace Phonebook?. Press **YES** to confirm or **NO** to cancel.

If the receiving handset memory is full, it displays Phonebook Memory Full. The sending handset displays Copying Unsuccessful.

Copy Phonebook from SIM

1. Open the SIM card drawer and remove it from the base station.

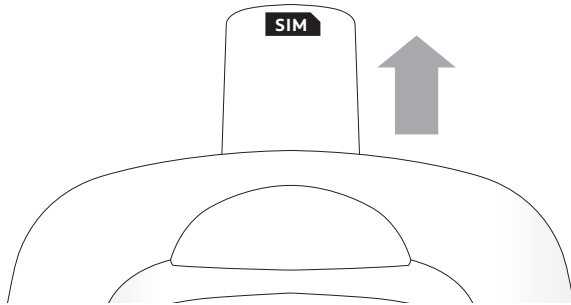

2. Insert SIM card between the retaining clips, microchip facing up, until it stops.

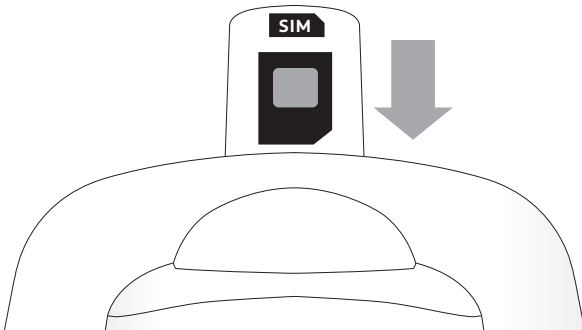

3. Slot the SIM card tray back in the base station and push in until it clicks.

If the SIM card format is not compatible, the display shows SIM Format Not Supported.

4. On the handset, press **NAMES**.

5. Scroll  or  to **Copy Phonebook** and press **SELECT**

6. Scroll  or  to **From SIM** and press **SELECT**







7. If requested, enter the SIM PIN number and press **OK**.

8. The Phonebook is copied. On completion the number of entries copied is displayed.

9. Press **BACK** to return to menu or press  to return to stand-by.





If the wrong pin is entered twice you will need to remove your SIM card from the CR2000 and re-insert it in to your mobile telephone to unlock it. Some SIM cards can store names up to 20 characters. When copying to the CR2000 handset, only the first 12 characters will be copied. Copying can be cancelled by pressing BACK or END CALL at any time during the process.

Copy entry to SIM

1. Insert SIM card in the SIM drawer of the base station
2. Press  in stand-by mode.
3. Scroll  or  to the entry and press **OPTIONS**.
4. Scroll  or  to **Copy Entry** and press **SELECT**.
5. Scroll  to **To SIM** then press **SELECT**.
6. If requested, enter the SIM PIN number and press **OK**. The entry is copied.
7. Press **BACK** to return to menu or press  to return to stand-by.

If the wrong pin is entered twice you will need to remove your SIM card from the CR2000 and re-insert it in to your mobile telephone to unlock it.

Copy Phonebook to another handset

1. Press **NAMES** in stand-by mode.
2. Scroll  or  to **Copy Phonebook** and press **SELECT**.
3. Press **SELECT** then scroll  or  to the destination handset number.
4. Press **SELECT** to begin copying. On completion the number of entries copied is displayed.
5. Press **BACK** to return to menu or press  to return to stand-by.





At the receiving handset:

1. The display shows **Replace Phonebook?**. Press **YES** to confirm or **NO** to cancel.

Copy Phonebook to SIM

1. Insert SIM card in the SIM drawer of the base station.

If the SIM card format is not compatible, the display shows SIM Format Not Supported.

2. Press **NAMES** in stand-by mode.
3. Scroll  or  to **Copy Phonebook** and press **SELECT**.
4. Scroll  or  to **To SIM** and press **SELECT**.
5. If requested, enter the SIM PIN number and press **OK**.
6. The Phonebook is copied. On completion the number of entries copied is displayed.
7. Press **BACK** to return to menu or press  to return to stand-by.

If the wrong pin is entered twice you will need to remove your SIM card from the CR2000 and re-insert it in to your mobile telephone to unlock it.
If the receiving SIM card memory is full, it displays **Memory Full Not All Copied**. The sending handset displays **Copying Unsuccessful**.

Dialling code



Your CR2000 feature automatically converts numbers from SIM cards stored with International codes as follows.

+61 is replaced by the local code 0.

+ is replace by the local code 0011

For instance , +442074030201 becomes 0011442074030201



Check Phonebook capacity

1. Press **NAMES** in stand-by mode.
2. Scroll  or  to **Memory Status** and press **SELECT**. The memory available is displayed.
3. Press **BACK** to return to menu or press  to return to stand-by.

Reminders

Reminders is a useful function that allows you to program your CR2000 to remind you of key events, such as birthdays and meetings.

To program a new reminder



1. Press **MENU** then scroll  or  to **Reminders** and press **SELECT**.
2. Press **SELECT** to **Add Event**
3. Enter in the name of the event (maximum of 24 characters) using the keypad, then press **SAVE**.
4. Enter the date and time the event is to occur, then press **SAVE**.
5. Press **SELECT** for **Silent** if you want a screen only based reminder, or scroll to **Alarm** and press **SELECT** if you want an audible reminder.

Note: If you select Alarm option then you can choose whether the event is a single occurrence, Once, or an annual event, Annually.

Note: If Once is your selected event occurrence, then you can set the time frame for the Alarm Reminder to sound, either at the time of the event, or 30 minutes prior.

6. Press  to return to standby.

You can edit an event by:

1. Press **MENU** then scroll  or  to **Reminders** and press **SELECT**.
2. Scroll to **Edit Event** then press **SELECT**
3. You can then edit the name of the event, the date and time of the event and the reminder options for the event.
4. Once editing is complete press  to return to standby.

The Reminders menu also gives you the option to Show Details of the event, Send the event as a Text, Delete Event and Delete All Events.

Telstra network services

The CR2000 Cordless Rental Phone includes the following one-touch feature keys:

Messagebank®³

If you are a Telstra Home Messages 101®⁴ and MessageBank®³ user, it's now even easier to retrieve your messages. Your CR2000 is programmed to access Telstra Home Messages 101® and MessageBank®.

To retrieve a message from your message service

1. Long press the  and follow the message service prompts.

Flashing Message Indicator⁶ (FMI)



The CR2000 is designed to provide visual message indication (a flashing red indicator). To arrange the connection to the Flashing Message Indicator⁶ feature, simply call Telstra on 13 2200. When a message is left in your MessageBank® service, a signal is sent to your telephone and the red indicator will flash and the words You Have New Voicemail will be displayed. The red indicator will stop flashing a short time after you have listened to all your messages.

Call Back⁵

Ever wasted time repeatedly trying to call someone and the line is busy? With Call Back you can have your call automatically completed as soon as the phone number you are calling is free.

How do I use Call Back?

When you make a call and hear a busy tone.

1. Long press , you will here an announcement.
2. Press 

To cancel a Call Back

1. Press 
2. Press    
3. Press 

To find out if you have a Call Back arranged

1. Press 
2. Press     
3. Press 

3-Way Chat⁵

This service is available on most lines ready for you to use! If you are already on a call, you can add another person and then have a 3-Way Chat.

How to use 3-Way Chat

To put existing call on hold and make a new call then to 3-Way Chat

1. Press 
2. Dial the second phone number
3. Long press 

To split a 3-Way Chat or switch between callers





1. Press 

Other Phone features

The CR2000 also provides you with quick access to 11 important phone features:

Personal Assistant	Call Wait Off	Call Forward Immediate Off	Call Forward Immediate check
MessageBank [®]	Check Call Wait	Call Forward No Answer On	Call Forward No Answer Check
Call Wait On	Call Forward Immediate On	Call Forward No Answer Off	

View and dial a Phone feature

1. Press **MENU**, scroll  or  to **Phone Features** and press **SELECT**.
2. Scroll  or  to the entry and press **OPTIONS**.
3. Press **SELECT** to choose **Show Details**.
4. Press **OPTIONS** then press **SELECT** to choose **Show Details**.
5. Press **DIAL** to call the number. If the number is a prefix, you can enter the rest of the number or add an entry from the Phonebook.
6. Press **BACK** to return to menu or press  to return to stand-by.

For more information on Telstra network services you can contact Telstra on 13 2200 or visit the web at www.telstra.com

Call Waiting²

If you have Call Waiting turned on the earpiece will emit a beep tone to inform you when there is a second incoming call. The number or name of the second caller will also be displayed if you have subscribed to Calling Number Display and caller's identity is not withheld. Please contact Telstra on 13 2200 for more information on this service.

1. To answer the second call and put your first call on hold, press .
2. To switch between both callers, press .
3. Press  to hang up on the person you are talking to and return to the caller on hold.

Calling Number Display⁷

If you have subscribed to Calling Number Display, and provided the identity of the caller is not withheld, the number or name if stored in the Phonebook of the caller will be displayed together with the date & time of the call.

With some incoming calls, if the telephone number is not available, the handset will display the following explanations:

UNAVAILABLE	the number is not available
PRIVATE	the caller has withheld their number
PAYPHONE	the caller is ringing from a payphone







When the Received Calls list is full, a new call replaces the oldest in the list.
The Received Calls list holds details of up to 50 calls. The Dialed Calls list holds up to 20 of the last numbers dialed.

Calls Lists

Calls Lists Missed Calls Received Calls Dialed Calls Delete Calls











The calls missed, received and dialed are displayed in chronological order with the most recent call at the top of the list. When the call log is empty, the screen displays **Call Lists Empty**. If you have missed calls, text messages or voicemail, the handset screen shows **You have new calls** or **You have new messages**

Access the Calls Lists

1. Press **MENU** and scroll  or  to **Calls Lists**.
2. Press **SELECT** and scroll  or  to the list you want **Missed**, **Received** or **Dialed**
3. Press **SELECT** then scroll  or  to view.









If a Calls List contains a number from your Phonebook, the name stored with the number will be displayed in the Calls Lists

Save number from the Calls List to the Phonebook







1. Press **MENU** and scroll  or  to **Calls Lists**.
2. Press **SELECT** and scroll  or  to the list you want **Missed**, **Received** or **Dialed**
3. Press **SELECT** then scroll  or  to the entry you want.
4. Press **OPTIONS** and scroll  or  to **Save Number**.
5. Press **SELECT** and enter a name. Press **OK**. The number is displayed.
6. Press **SAVE** and scroll  or  to select the ringer melody. Press **SELECT** to confirm.
7. Press **BACK** to return to menu or press  to return to stand-by.

If the number your are trying to save is already in your Phonebook, the number cannot be saved again. If you try to save an existing number you will hear an error tone. Press  to return to standby.

Delete a Calls List entry



1. Press **MENU** and scroll  or  to **Calls Lists**.
2. Press **SELECT** and scroll  or  to the list you want **Missed**, **Received** or **Dialled**
3. Press **SELECT** then scroll  or  to the entry you want.
4. Press **OPTIONS**. Scroll  or  to **Delete Call** and press **SELECT**.
5. Press **BACK** to return to menu or press  to return to stand-by.

Delete all entries in a Calls List







1. Press **MENU** and scroll  or  to **Calls Lists**.
2. Press **SELECT** and scroll  or  to **Delete Calls**.
3. Press **SELECT** then scroll  or  to **Missed**, **Received**, **Dialled** or **All Calls**. and press **SELECT**.
4. Press **YES** to confirm or **NO** to cancel.
5. Press **BACK** to return to menu or press  to return to stand-by.

You can delete all entries in any one of the Calls Lists or all entries in all Calls Lists.

Access the redial list

1. Press **UP** from stand-by and scroll  or  to view the entries.

Save redial list entry to Phonebook

1. Press **UP** from stand-by and scroll  or  to view the entries.
2. Press **OPTIONS** and scroll  or  to **Save Number**
3. Press **SELECT** and enter a name. Press **SELECT**. The number is displayed.
4. Press **SELECT** and scroll  or  to select the ringer melody. Press **OK** to confirm.
5. Press **BACK** to return to menu or press  to return to stand-by.

Delete number from redial list

1. Press **UP** from stand-by and scroll  or  to the number.
2. Press **OPTIONS**. Scroll  or  to **Delete Call** and press **OK**.

Text Messaging (SMS)¹

Your Telstra CR2000 cordless rental phone can send text messages to and receive text messages from compatible mobile telephones and compatible fixed line telephones in Australia.

In accordance with worldwide standards for text messaging, all messages (including reply messages) will display the telephone number of the sender. If you have a Silent Line or have blocked Calling Line Identification and attempt to send a message, your message will be rejected. To alter your service so that you can send text messages, call the Telstra Fixed Phone text service on 0198339999 and use the setup menu to turn off Silent Line or Calling Line Identification blocking for text messaging ONLY.

Note- For information on how to use Telstra text messaging service call 0198339999 and follow the voice prompts.

You can create up to 4 extra text message mail boxes, Box 1 to Box 4, and protect each box with a password. Mailbox 0 with an empty password is created by default. In order to send and receive text messages, there must be at least one general text message mailbox 0.

Your CR2000 can store up to 50 text messages in the inboxes, draft folders, and outboxes. You can set the maximum length of each message - either 160 characters or 612 characters page 48. For more information, please refer to “Mailboxes” on page 46.

Write and send new text message

1. Press **MENU** from stand-by mode, press **SELECT** to choose **Text Messaging Menu** and press **SELECT** again to choose **Write Message**.

Key



Operation

Press to move cursor left

Press to move cursor right.



Press and hold to jump to the last character/digit.

BACK

Press to delete the previous character/digit.

Press to return to the previous menu if no text or digits have been entered.

Long press to delete all text entered.

2. Enter the text and press **OPTIONS**. Press **SELECT** to choose **Send To**.
3. Enter the destination number or press **SEARCH** to scroll  or  through the Phonebook to the name. Then press **SELECT**.
4. Press **SEND** the message will be sent immediately. **Message Sent** will be displayed if the message has been sent successfully.

If you receive a call while writing a text message, the operation will be interrupted. However, your text message will be saved and will appear when you return to the **Write Message** screen.









When a message is sent, a copy is kept in the Outbox with details of the time and date it was sent.

If the message cannot be sent, the screen shows **Message Sending Failed**. Your CR2000 will try to send the text three times at 10 minute intervals. If message sending still fails a copy is kept in the Drafts folder.

WARNING When composing your text message, if no keys are pressed for 60 seconds, the handset will return to stand-by mode.



The edited message will be automatically saved and will appear when you return to the **Write Message** screen.

Send a message to a number in a calls list

1. Press **MENU**, scroll  or  to **Calls Lists** and press **SELECT**.
2. Scroll  or  to **Missed**, **Received** or **Dialled** and press **SELECT**.
3. Scroll  or  to the number or name and press **OPTIONS**.
4. Scroll  or  to **Send Message** and press **SELECT**.
5. Write your message, press **OPTIONS** and press **SELECT** to choose **Send**.
6. Press **SEND** to send the message. If send is successful the display shows **Message Sent**.





WARNING When the maximum number of messages has been reached, the display will show **Memory Full Delete Messages**. You must delete some messages in order to send or receive new ones.

Save a message





1. Press  or Press **MENU** from stand-by, press **SELECT** to choose Text Messaging Menu and press **SELECT** again to choose Write Message.
2. Enter the text and press **OPTIONS**. Scroll  to Save and press **SELECT**. The text is saved in the Drafts folder.

You can save a message for sending later.

Insert a symbol





1. Press  or press **MENU** from stand-by, press **SELECT** to choose Text Messaging Menu and press **SELECT** again to choose Write Message.
2. Enter the text. When ready to insert the symbol press **OPTIONS**. Scroll  to Insert Symbol and press **SELECT**. Press  or  to select the symbol and press **INSERT**.
3. Continue adding text until finished then send the message as normal.

Insert Emoticon

1. Press  or press **MENU** from stand-by, press **SELECT** to choose Text Messaging Menu and press **SELECT** again to choose Write Message.
2. Enter the text. When ready to insert the emoticon, press **OPTIONS**. Scroll  to Insert Emoticon and press **SELECT**. Press  or  to select the emoticon and press **INSERT**.
3. Continue adding text until finished then send the message as normal.





Insert Template

Choose from 3 pre-set templates: *Please call, I'll be there at and What time will you be home?*

1. Press  or press **MENU** from stand-by, press **SELECT** to choose Text Messaging Menu and press **SELECT** again to choose Write Message.
2. Enter the text. When ready to insert the template, press **OPTIONS**. Scroll  to Insert Template and press **SELECT**. Press  or  to select the template and press **INSERT**.
3. Continue adding text until finished then send the message as shown in steps 3-5 of 'Write and send new text message' on page 38.







TIP When writing a message, the screen displays the number of available characters counted down from 160 to 0. To change the message size to 612 characters, see page 48.

Edit Template





1. Press  or press **MENU** from stand-by, press **SELECT** to choose **Text Messaging** menu and scroll  to **Templates** and press **SELECT**.
2. Scroll  or  to the template and press **OPTIONS**.
3. Press **SELECT** to choose **Edit**.
4. Change the text as required and press **SAVE**. The new template is stored in the list.
5. Press  to return to standby.

A template can up to a maximum of 32 characters long.

Delete Template

1. Press  or press **MENU** from stand-by, press **SELECT** to choose **Text Messaging** menu and scroll  to **Templates** and press **SELECT**.
2. Scroll  or  to the template and press **OPTIONS**.
3. Scroll  to **Delete** and press **SELECT**.
4. Press **YES** to confirm or **NO** to cancel.
5. Press  to return to standby.

Send text message to previously dialled number



1. Press **MENU** scroll down to **Calls Lists** and press **SELECT**.
2. Scroll  or  to **Dialled Calls** and press **SELECT**.
3. Press **OPTIONS**, scroll  or  to **Send Message** and press **SELECT**.
4. Write your message then press **OPTIONS**.
5. Press **SELECT** to choose **Send**. The number is displayed. Press **SEND**.

Inbox

The messages in the Inbox are listed according to the time of receipt, with the newest message appearing first. The Inbox can store up to 50 messages. Each time an text message is received the screen displays the number of new messages received.

WARNING When the maximum number of messages has been reached, the display will show **Memory Full Delete Messages**. You must delete some messages in order to send or receive new ones.

View messages in the main Inbox

1. Press  or press **MENU** then **SELECT** to choose **Text Messaging** menu, scroll  to **Inbox** and press **SELECT**.
2. Scroll to your desired message then press **READ**. The message is displayed.

TIP While reading a text message, press  or  : to scroll to the next or previous row.

3. When viewing the message content, you can press **OPTIONS** to access the following:

Reply	Send a reply to the sender of the message.
Forward	Send the message on to another number.
Message Detail	View the sender's number and time and date of reception.
Use Number	Call the sender's number or Save it to the Phonebook
Delete	Delete the text message.

4. To return to text messaging menu, press **BACK**.

View messages in an individual mailbox

Your CR2000 has 1 general inbox and allows up to 4 additional individual mailboxes which can be password protected for extra privacy.

To set an individual user mailbox, see page 46.

1. Press  or press **MENU** then **SELECT** to choose **Text Messaging** menu.

The available user mailboxes and the common mailbox are listed.

Scroll  or  to the mailbox you want and press **OK**.

2. Scroll  to **Inbox** and press **SELECT**.
3. Scroll to your desired message then press **READ**. The message is displayed.
4. When viewing the message content, you can press **OPTIONS** to access the following:

Reply	Send a reply to the sender of the message.
Forward	Send the message on to another number.
Message Detail	View the sender's number and time and date of reception.
Use Number	Call the sender's number or Save it to the Phonebook
Delete	Delete the text message.

4. To return to text messaging menu, press **BACK**.



Reply to an Inbox message

1. While viewing the message, press **OPTIONS** then **SELECT** to choose **Reply**.
2. Press **SELECT** and write your reply message..
3. Send the message as shown in steps 3-5 of 'Write and send new text message' on page 38.



Forward an Inbox message

1. While viewing the message, press **OPTIONS**, scroll  to **Forward** and press **SELECT**.
The message is displayed again so you can edit if you wish.
2. After editing, press **OPTIONS**
3. Send the message as shown in steps 3-5 of 'Write and send new text message' on page 38.





View message details

1. While viewing the message, press **OPTIONS**, scroll  to **Message Details** and press **SELECT**.
2. The sender's details, phone number, date and time of reception are displayed.
3. Press **DIAL** to call the sender or  to return to stand-by.

Call a sender's number

1. While viewing the message, press **OPTIONS**, scroll  to **Use Number** and press **SELECT**.
2. Scroll  or  to choose **Call** and press **SELECT**. The number is dialled.

Save a sender's number

1. While viewing the message, press **OPTIONS**, scroll  to **Use Number** and press **SELECT**.
2. Scroll  or  to choose **Save** and press **SELECT**.
3. Enter the name and press **OK**. The number is displayed, press **SAVE** and scroll  or  to the desired ringer melody and press **SELECT**.
4. The Inbox screen is displayed again.





Delete an Inbox message

1. While viewing the message, press **OPTIONS**, scroll  to **Delete** and press **SELECT**.
2. Press **YES** to confirm or **NO** to cancel.

Draft Box

In addition to text messages saved as drafts, all the text messages that are not successfully sent will be automatically stored in the Draft Box. The Draft Box can store up to 50 messages.

Review or Edit Draft messages

1. Press  or press **MENU**, press **SELECT** to choose **Text Messaging** menu and press **SELECT**.
2. Scroll  to **Drafts** and press **SELECT**.
3. If you have more than one message, scroll  or  to your desired message and press **SELECT**.
4. When reviewing the message content you can press **OPTIONS** to begin editing your text. Press **OPTIONS** again to access the following:
 - Send
 - Save
 - Insert Symbol
 - Insert Emoticon
 - Insert Template
5. Send the message as shown in steps 3-5 of *'Write and send new text message'* on page 38.

Edit a message in Draft Box

WARNING When the maximum number of messages has been reached, the display will show **Memory Full Delete Messages**. You must delete some messages in order to send or receive new ones.

Send a message from Draft Box





1. While viewing the message, press **OPTIONS**.
2. Send the message as shown in steps 3-5 of *'Write and send new text message'* on page 38.

Outbox

The Outbox contains messages that have been sent. The Outbox can store up to 50 messages.

The Outbox lets you view messages you have sent and forward messages to other people without having to re-write a new message.



View a message in the Outbox

1. Press **MENU** then **SELECT** to choose Text Messaging menu.
2. Scroll  or  to **Outbox** and press **SELECT**. Scroll  or  to the text message and press **SELECT**.
3. When viewing a message you can press **OPTIONS** to access the following:
 - Forward
 - Delete
4. Press  to return to stand-by.

Forward a message from the Outbox









1. When viewing a message in the Outbox, press **OPTIONS** then **SELECT** to choose FORWARD.
2. If necessary edit the text message then press **OPTIONS**.
 - Send
 - Save
 - Insert Symbol
 - Insert Emoticon
 - Insert Template
3. Press **SELECT** then enter the phone number or press **SEARCH** to choose a number from the Phonebook and press **SEND**.
4. Press  to return to stand-by.

Delete messages from the Outbox

1. When viewing a message in the Outbox, press **OPTIONS**, scroll  to **Delete** and press **SELECT**.
2. Press **YES** to confirm or **NO** to cancel.
3. Press  to return to stand-by.







Delete messages

Delete messages in a folder - either the Inbox or Drafts or Outbox.

1. Press  or press **MENU** then **SELECT** to choose **Text Messaging Menu**.
If you have set user mailboxes, scroll  or  to the mailbox and press **SELECT**.
2. Scroll  or  to **Delete Message** and press **SELECT**.
3. Scroll  or  to **Inbox**, **Drafts** or **Outbox** and press **SELECT**.
4. Press **YES** to confirm or **NO** to cancel.
5. Press  to return to stand-by.

Delete all messages

Delete all messages in all Inbox, Drafts, Outbox and Delivery Reports folders.

1. Press **MENU** then **SELECT** to choose **Text Messaging menu**.
If you have set user mailboxes, scroll  or  to the mailbox and press **SELECT**.
2. Scroll  or  to **Delete Message** and press **SELECT**.
3. Scroll  or  to **All Messages** and press **SELECT**.
4. Press **YES** to confirm or **NO** to cancel.
5. Press  to return to stand-by.

Text message settings

The text message settings menu allows you to:









- set a mailbox number
- set up the server for sending and receiving text message messages
- set the message size to 160 or 612 characters
- activate/deactivate message alert

Mailboxes

All messages are initially received or sent from the default mailbox which has a terminal number of 0. You can add up to 4 other user mailboxes. This gives your CR2000 a total of 5 available mailboxes.

Add user mailboxes

You can set up to 4 individual mailboxes and include a password to help keep messages private.







1. Press  or press **MENU** then **SELECT** to choose Text Messaging menu.
2. Scroll  or  to Text Settings and press **SELECT**.
3. Scroll  or  to Users and press **SELECT**.
4. Scroll  or  to select the User mailbox and press **OPTIONS**.
5. Press **SELECT** to choose Edit and enter a name maximum of 8 characters for the mailbox, e.g. Mike.
6. Press **SAVE**. The mailbox number allocated by the CR2000 is displayed. Press **SAVE**.
7. Enter the 4 digit PIN password and press **SAVE**.
8. Re-enter the PIN if used and press **SAVE**.
9. Add another user or press  to return to stand-by.

If you do not enter a mailbox PIN, the mailbox is not password protected.

Receive a message to a mailbox









To receive a text into an individual mailbox, the sender must add the relevant mailbox number 1, 2, 3 or 4 to the end of your phone number. If no mailbox number is added, the message will be received into the general mailbox.

View messages in a mailbox









1. Press  or press **MENU** then **SELECT** to choose **Text Messaging** menu.
2. Scroll  or  to the mailbox name and press **SELECT**.
3. Enter the 4-digit mailbox PIN and press **OK**.
4. Scroll  or  to **Inbox** and press **SELECT**.
5. Press  or  if required to scroll through the text message.

Edit a user mailbox

Change the mailbox name and 4-digit password.









1. Press  or press **MENU** then **SELECT** to choose **Text Messaging** menu.
2. Scroll  or  to the mailbox name and press **SELECT**.
3. Enter the 4-digit mailbox PIN and press **OK**.
4. Scroll  or  to **Users** and press **SELECT**.
5. Scroll  or  to select the User mailbox and press **OPTIONS**.
6. Press **SELECT** to choose **Edit** and edit the name.
7. Press **SAVE**. The mailbox number is displayed. Press **SAVE**.
8. Enter a new 4 digit PIN password and press **SAVE**.
9. Re-enter the PIN and press **SAVE**.
10. Edit another user or press  to return to stand-by.

Delete a user from a mailbox

1. Press  or press **MENU** then **SELECT** to choose **Text Messaging** menu.
2. Scroll  or  to the mailbox name and press **OPTIONS**.
3. Enter the 4-digit mailbox PIN and press **OK**.
4. Scroll  or  to **Users** and press **SELECT**.
5. Scroll  or  to select the User mailbox and press **OPTIONS**.
6. Scroll  to **Delete** and press **SELECT**.
7. Press **YES** to confirm or **NO** to cancel.
8. Enter the 4 digit PIN password. The user name is deleted.
9. Delete another user or press  to return to stand-by.









Set message size

Standard text message size is 160 characters, your CR2000 can send long messages up to 640 characters in one transaction. Messages over 160 characters may be delivered as separate messages of 160 characters each depending on the receiving phone. Each unit of 160 characters will be charged as for a separate message. Choose from 160 or 612 characters.

1. Press  or press **MENU** then **SELECT** to choose Text Messaging menu.
2. Scroll  or  to Text Settings and press **SELECT**.
3. Scroll  or  to Message Size and press **SELECT**.
4. Scroll  or  to select the default message size and press **SELECT**.
5. Press  to return to stand-by.

Message Alert

A tone is emitted when a new text message is received. You can switch this Text Message Alert Tone On or Off. By default, Text Message Alert tone is On.

1. Press  or press **MENU** then **SELECT** to choose Text Messaging menu.
2. Scroll  or  to Text Settings and press **SELECT**.
3. Scroll  or  to Message Alert and press **SELECT**.
4. Scroll  or  to select On or Off and press **SELECT**.
5. Press  to return to stand-by.

Service Centres







Your CR2000 can send and receive messages via 2 service centres. Each of the incoming and outgoing service centre numbers are programmed with the Telstra default service centre numbers:

- Incoming number - **01983391**
- Outgoing number - **01983391**

Note: The default service centre for receive and send is No 1. If you change the numbers or the service centres from the default values you may not be able to send or receive text messages on Telstra's network.







To set outgoing number

The incoming and outgoing numbers of your CR2000 are already set to work on Telstra's network. We advise you not to modify these settings. For more details or in case of any problems, please contact your local network provider.

1. Press  or press **MENU** then **SELECT** to choose Text Messaging menu.
2. Scroll  or  to Text Settings and press **SELECT**.
3. Press **SELECT** again to open the Service Centres menu, scroll  to Send Centres and press **SELECT**.
4. Scroll  or  to select Send Centre 1 or 2 and press **SELECT**.
5. Enter the number and press **SAVE**.
6. Press  to return to stand-by.

The maximum length of an outgoing number is 24 digits.







To set incoming number

1. Press  or press **MENU** then **SELECT** to choose Text Messaging menu.
2. Scroll  or  to Text Settings and press **SELECT**.
3. Press **SELECT** again to open the Service Centres menu, scroll  to Incoming Centre and press **SELECT**.
4. Scroll  or  to select Receive Centre 1 or 2 and press **SELECT**.
5. Enter the number and press **SAVE**. This sets the Receive Centre selected as the default setting
6. Press  to return to stand-by.

The maximum length of an incoming number is 24 digits.

Set default Text Message send centre

The default Text Message centre is 1.





1. Press  or press **MENU** then **SELECT** to choose Text Messaging menu.
2. Scroll  or  to Text Settings and press **SELECT**.
3. Press **SELECT** again to open the Service Centres menu, scroll  to Set Send Centre and press **SELECT**.
4. Scroll  or  to select Send Centre 1 or 2 and press **SELECT** to confirm
5. Press  to return to stand-by.

Register an additional handset

Register an additional handset

Follow these steps when registering an additional CR2000 handset.





To register an additional handset

1. Press *and hold*  on the base station for 3 seconds in stand-by mode. The base will emit 2 beeps and the Power/In Use light will begin to flash. You have up to 60 seconds to complete the registration procedure.
2. The additional handset display shows `Please Register`.
3. Press **MENU** then scroll  or  to `Registration`
4. Press **SELECT** and then scroll  or  to the base you want.
5. Press **SELECT** and enter the System PIN original setting `0000`.
6. Press **OK**.

Switch bases

If you are registered to more than one base, you can switch between them.







To switch bases

1. At the handset, press **MENU** then scroll  or  to `Registration` and press **SELECT**.
2. Scroll  to `Select Base`.
3. Press **SELECT**. `In Use` is shown next to the base currently being used by the handset. Scroll  or  to select the Base.
4. Press **SELECT**.

De-register a handset

You can use one handset to de-register another.

To de-register a handset

1. Press **MENU**.
2. Scroll  or  to **Registration** and press **SELECT**.
3. Scroll  or  to **De-register** and press **SELECT**.
4. Enter the System PIN original setting **0000** and press **OK**.
5. Scroll  or  to the handset to be de-registered and press **SELECT**.
6. Press **YES** to confirm or **NO** to cancel.

Troubleshooting

The BATTERY icon is not blinking when the handset is placed on the base

- Bad battery contact – move the handset slightly
- Dirty contact - Clean the battery contact with a cloth moistened with alcohol
- Battery is full – no need to charge

No dialling tone

- No power - check the connections. Reset the phone: unplug and plug back in the mains
- Batteries are empty - charge the batteries for at least 24 hours
- You are too far from the base station - move closer to the base station
- Wrong line cable - use the line cable provided
- Line adaptor when needed is not connected to the line cord - connect the line adaptor when needed to the line cord

Poor audio quality

- You are too far from the base station - move closer to the base station
- The base station is too close to electrical appliances, reinforced concrete walls or metal doorframes - move the base station at least one metre away from any electrical appliances
- ADSL Broadband requires correct filter for Digital DECT cordless telephones. If unit functions without interference when ADSL modem is not connected to the line then filter is not suitable.

The range icon is blinking

- Handset is not registered to the base station - register the handset to the base station
- You are too far from the base station - Move closer to the base station

The copy from my mobile phone SIM card to CR2000 Phonebook is not complete.

- Only Phonebook entries from your mobile phone SIM card will be transferred - so transfer entries on your mobile phone memory to your mobile phone SIM card and then to your CR2000.

The handset display is not available.

- Try again by disconnecting and connecting the base station power supply and follow the procedure to register a handset see page 50. Remove and place back the handset batteries

The handset display is not available.- when attempting to add another handset to the base station

- Maximum number of 5 handsets has been reached – de-register a handset in order to register a new one.

The handset display is not available.- when using a handset

- Base station may be busy with another handset. Wait until it is available.

Noise interference on your radio or television

- Your base station or charger may be too close. Move it as far away as possible

Caller Line Identification CLI service does not work

- Check your subscription with your network operator

No ring

- The ring is switched off. Increase the volume

A Phonebook entry cannot be stored

- The Phonebook is full. Delete an entry to free memory

Cannot receive new Text Message

- Text Message storage space is full. Delete old Text Message
- Wrong Text Message settings. Check your Text Message settings see page 46

Cannot send or receive new text message

- The outgoing or incoming text message centre numbers are not set or are wrong. Refer to “text message settings” on page 48.
- Another SMS-enabled phone is also on your line. If you have more than one text message capable phone on the same line, the phones may not be able to operate properly when receiving text messages. To overcome this you should change the terminal number on one of the phones so that only one phone has a terminal number of 0. The phone with the terminal number of 0 will receive all the text messages sent to your default address. The other phone will only receive text messages sent to the specific terminal sub-address.

General Information

Replacing the handset batteries

After a time, you may find that the handset batteries are running out of charge more quickly. This is a standard sign of wear and the batteries will need replacing. For replacement rechargeable NiMH batteries contact your local electrical retailer.

Replacement batteries

Type: AAA Nickel Metal Hydride (NiMH)

Quantity: 2

Capacity 750 mAH

Slide off the battery compartment cover and remove existing batteries. Insert new batteries and replace the compartment cover.

IMPORTANT

This equipment is not designed for making emergency telephone calls when the power fails. Alternative arrangements should be made for access to emergency services.

Safety

General

- Only use the power supply included with the product.
- Use only the approved rechargeable batteries supplied. Spare rechargeable batteries are available from your local electrical retailer.
- Do not open the handset (except to replace the handset batteries) or the base. This could expose you to high voltages or other risks.
- Radio signal transmitted between the handset and base may cause interference to hearing aids.
- It is recommended that advice from a qualified expert be sought before using this product in the vicinity of emergency/intensive care medical equipment.
- Your product may interfere with other electrical equipment, e.g. TV and radio sets, clock/alarms and computers if placed too close. It is recommended that you place your product at least one metre away from such appliances to minimise any risk of interference.
- Never dispose of batteries in a fire. There is a serious risk of explosion and/or the release of highly toxic chemicals.

Cleaning

Simply clean the handset and base with a damp (not wet) cloth, or an anti-static wipe. Never use household polish as this will damage the product. Never use a dry cloth as this may cause a static shock.

Environmental

- Do not expose to direct sunlight.
- The Telstra CR2000 may heat up when the batteries are being recharged or during prolonged periods of use. This is normal. However, we recommend that to avoid damage you do not place the Telstra CR2000 on antique/veneered wood.
- Do not stand your Telstra CR2000 on carpets or other surfaces, which generate fibres, or place it in locations preventing the free flow of air over its surface.
- Do not submerge any part of your Telstra CR2000 in water and do not use it in damp or humid conditions, such as bathrooms.
- Do not expose your Telstra CR2000 to fire, explosive or other hazardous conditions.
- There is a slight chance that your Telstra CR2000 could be damaged by an electrical storm. We recommend that you unplug the power and telephone line cord from the base for the duration of the storm.

How many telephones can you have?

All items of telephone equipment have a Ringer Equivalence Number (REN), which is used to calculate the number of items, which may be connected to any other telephone line. Your Telstra CR2000 has a REN of 0.1. A total REN of 3 is allowed, if the total REN of 3 is exceeded, the telephone may not ring. With different telephone types there is not guarantee of ringing, even when the REN is less than 3.

Product Service, Terms and Conditions

Rental terms and conditions

Your CR2000 cordless rental telephone is subject to the terms and conditions set out in Part A - General of the Basic Telephone Service Section of Our Customer Terms, which is available for inspection at most Telstra shops or at www.telstra.com.au/customerterms/index.htm.

Rental telephone faults

For any service difficulties and faults call 13 2203 for Residential or 13 2255 for Small Business customers or check the Telstra White Pages® directory for further contact numbers.

Things you need to know

1. For most Telstra and Telstra reseller customers for messages between compatible services. Charges apply.
2. Available on most fixed phones
3. Monthly charge and call charges apply
4. Available to most Telstra home phone access customers.
5. Usage and call charges apply. Excludes some calls
6. To arrange connection of Flashing Message Indicator service call Telstra on 132200
7. Excludes blocked calls. Monthly charge applies. Available in most areas.

© COPYRIGHT 2006 Telstra Corporation Limited

This work is copyright. All rights reserved. Other than for purposes and subject to conditions prescribed under the Copyright Act, no part of it may in any form or by any means (electronic, mechanical, photo copying, microcopying, scanning, recording or otherwise) be reproduced, stored in a retrieval system or transmitted without prior permission from Telstra Corporation Limited ABN 33 051 775 556.

™ Trade Mark of Telstra Corporation Limited

® Registered Trade Mark of Telstra Corporation Limited



www.telstra.com

