

TELSTRA 13950 DECT6.0 CORDLESS PHONE WITH VIDEO DOORBELL

USER GUIDE

This telephone has been designed for ease of use.

Please read the instructions and keep it handy for future reference.

If you have any problems with your phone, refer to the Help section of this User Guide.

IT'S HOW
WE CONNECT



INTRODUCTION

To your Telstra 13950 DECT6.0 Cordless Phone with Video Doorbell

- Doorbell – The doorbell takes photos and streams video and/or audio to the cordless handsets.
- Phonebook – The home phonebook stores up to 50 entries.
- Telstra's Calling Number Display* lets you see who's calling. Your phone stores details of the last 30 callers in the Call List.
- Answering machine, with up to 15 minutes digital recording time and helpful voice prompts.

* IMPORTANT

You need to subscribe to Telstra's Calling Number Display service to be able to see the caller's number or name when called, or in the Calls List. See page 58 for more details.

This User Guide provides you with all the information you need to get the most from your phone. Before you make your first call, you will need to set up your phone. Follow the simple instructions on the next few pages.

NEED HELP?

PLEASE LOOK IN THE HELP SECTION AT THE END OF THE USER GUIDE IF YOU EXPERIENCE ANY OPERATIONAL DIFFICULTIES WITH YOUR TELSTRA PRODUCT, OR PLEASE CONTACT THE TECHHELP INFORMATION LINE 1300 369 193 OR CONTACT US BY EMAIL AT: tcpsupport_au@vtech.com

GOT EVERYTHING?

The package contains the following items:

- Telstra 13950 cordless handset
- Battery compartment cover
- AAA NiMH battery pack
- Telstra 13950 telephone base
- AC power adaptor
- Doorbell with wall mount cover
- 2 Screws for doorbell wall mount
- 2 Wall anchors
- Screw for doorbell (bottom)
- Telephone line cord
- Wall mount bracket
- 2 AA Alkaline batteries
- Telephone plug
- 1 User guide

If you have purchased Telstra 13950 Multi-handset pack, you will also have the following for each additional handset:

- Telstra 13950 cordless handset
- Battery compartment cover
- AAA NiMH battery pack
- Telstra 13950 handset charger with charger adaptor

IN THIS GUIDE

Important safety instructions	9
Getting started	11
Location	11
Setting up	11
Installation options	25
Re-chargeable battery low warning	29
Re-chargeable battery performance	29
Date and time	30
Getting to know your phone	31
Telephone base buttons	31
Handset buttons	33
Doorbell buttons	36
Handset and telephone base display	37
Navigating the menus	38
Handset menu layout	39
Keystroke table	40
Using the doorbell	41
Make and answer a chime	41
Start a video streaming session	41
Extend a video streaming session	41
End a video streaming session	41
Answer an incoming call during video streaming	42
View captured photos	42

Delete a captured photo	42
Delete all captured photos	42
Night vision	42
Using the phone	43
Make, predial, answer or end a call	43
Handset speakerphone	43
Volume control	43
Mute	43
Temporary ringer silencing	44
Chain dialing	44
PAGE handset	45
Redial	45
Equalizer	45
Transfer a call	46
Join a call in progress	46
Intercom	46
Answer an incoming call during an intercom call	47
Call transfer using intercom	47
Phonebook	49
Add a phonebook entry	49
Review phonebook entries	49
Alphabetical search	49
Dial a phonebook entry	50
Edit a phonebook entry	50
Delete a phonebook entry	50

Speed dial	51
Assign a speed dial entry	51
Reassign a speed dial entry	51
Delete a speed dial entry	52
Dial a speed dial number	52
Phone settings	53
Using the menu	53
Ringer volume	53
Ringer tone	53
Chime volume	54
Chime tone	54
Quiet mode	54
Set date and time	55
Calling Number Display Voice announce [®]	55
Clear voicemail indicators	55
Rename base/handset	56
Key tone	56
LCD brightness	56
Dim mode	57
Wallpaper	57
Telstra network services*	58
Calling Number Display	58
Memory match	59
Call list display screen message	59
Missed call indicator	60
Review the call list	60

Dial a call list entry	60
Save a call list entry to the phonebook	60
Delete call list entries	61
Flashing message indicator (FMI)	61
Telstra home messages 101 [®] or messageBank [®]	62
Call waiting	62
3-Way chat	63
Answering machine	64
Announcement	64
Record your own announcement	64
Play your announcement	65
Delete your announcement	65
Answer on/off	65
Call screening	66
Number of rings	66
Remote access code	66
Message alert tone	67
Message recording time	67
Answering machine and voicemail	68
Message capacity	69
New message indication	69
Call screening	69
Call intercept	70
Temporarily turn off the message alert tone	70
Message playback	70
Delete all old messages	71
Record, play and delete memos	72

Remote access	72
Help	74
General information	85
Replacing the handset battery	85
Safety	85
Cleaning	86
Environmental	86
How many telephones can you have?	87
Customer service & Product warranty	88

IMPORTANT SAFETY INSTRUCTIONS

When using your telephone equipment, basic safety precautions should always be followed to reduce the risk of fire, electric shock and injury, including the following:

1. Read and understand all the instructions.
2. Follow all warnings and instructions marked on the product.
3. Unplug this product from the wall outlet before cleaning. Do not use liquid or aerosol cleaners. Use a damp cloth for cleaning.
4. Do not use this product near water (for example, near a bath tub, kitchen sink, swimming pool) or in humid areas.
5. Do not overload wall outlets and extension cords as this can result in the risk of fire or electric shock.
6. Unplug this product from the wall outlet and contact TechHelp on 1300 369 193 under the following conditions:
 - When the power supply cord or plug is damaged or frayed.
 - If the product does not operate normally by following the operating instructions.
 - If the product has been dropped and the outer casing has been damaged.
 - If the product exhibits a distinct change in performance.
7. Avoid using a telephone during an electrical storm. There may be a remote risk of electric shock from lightning.
8. Do not use the telephone to report a gas leak in the vicinity of the leak.
9. Use only the supplied NiMH (Nickel Metal Hydride) battery. The operation periods for the handsets are only applicable with the default battery capacity.
10. The use of other battery types or non rechargeable batteries/primary mobile batteries can be dangerous. These may cause interference and/or unit damage. Telstra will not be held liable for damage arising from such noncompliance.
11. Use only the AC power adaptors supplied with this product. Please contact TechHelp on 1300 369 193 for replacement adaptors.

12. Please ensure that the battery is inserted according to the correct polarity as indicated on the re-chargeable battery and the internal markings inside the handset battery compartment.
13. Do not immerse the battery in water, and do not place them in a fire.
14. Telephone receivers produce magnetic fields that can attract small metallic objects such as pins or staples. To avoid injury, do not place the handset where such objects can be picked up.

GETTING STARTED

LOCATION

Place your Telstra 13950 within 2 metres of the mains power socket and telephone socket so that the cables will reach.

Make sure it is at least 1 metre away from other electrical appliances to avoid interference. Your Telstra 13950 works by sending radio signals between the base, handset and doorbell. The strength of the signal depends on where you locate the base. Putting it as high as possible ensures the best signal.

The maximum range between the base station and the handset is approximately 300 meters.

SETTING UP

Telephone base installation

1. Plug the mains power adapter cable into the base station, plug the other end of the mains power adapter into a mains power wall socket.

Note: Ensure power cord is fed through slot on base so unit sits flush with the desk.

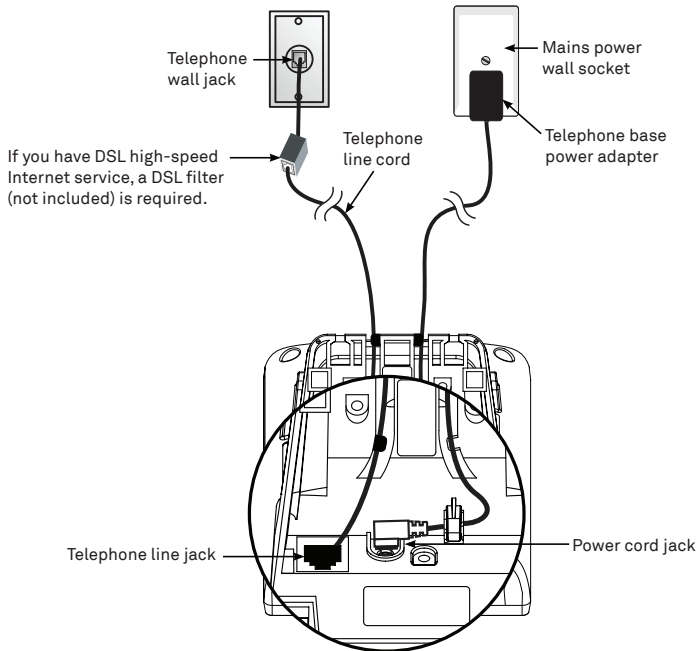

2. Insert one end of the telephone line cord into the base station and the other end of the telephone line cord into a telephone wall jack. If you have DSL high speed internet service, a DSL filter (not included) is required.

CAUTION:

If you subscribe to telephone service from a cable company or a VoIP service provider, plug the telephone line cord into the modem/router/terminal adapter provided by your cable/VoIP service provider. Contact your cable/VoIP service provider if you have any difficulties in installation.

Handset battery installation

1. Insert the battery connector securely into the socket, matching the orientation of the engraved label.
2. Place the battery with the label **IMPORTANT** facing up and the wires inside the battery compartment.

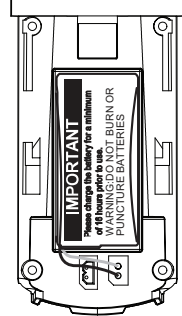
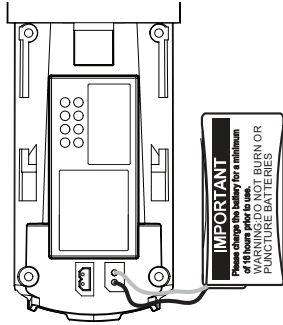

3. Align the cover flat against the battery compartment, then slide it towards the center of the handset until it clicks into place.

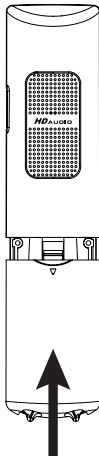

Charger installation

1. Plug the power cable into the charger base.

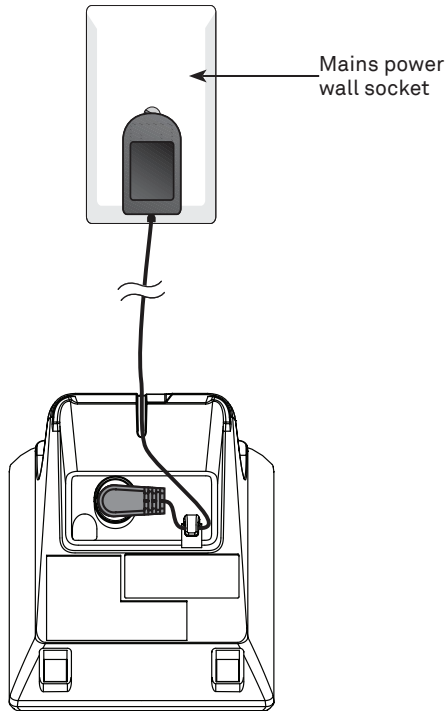

2. Plug the other end into the a mains power wall socket.
3. Place the handset in the handset charger to charge.

Note: Ensure power cord is fed through slot on base so unit sits flush with the desk.

Doorbell battery installation

1. Remove the wall mount cover at the back.
2. Install two AA batteries into the battery compartment, matching the polarity markings (+ and -) inside the battery compartment.

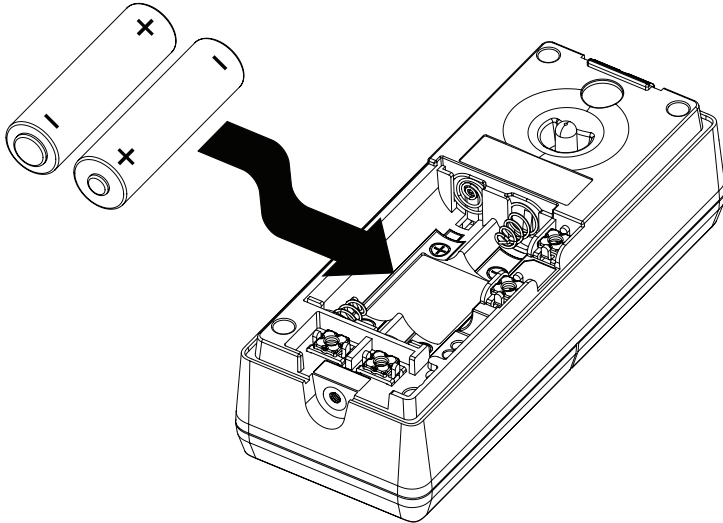









Locating the doorbell

Before mounting the doorbell on a wall, make sure you test if the location you install the doorbell is in range, and adjust the camera angle to best suit your needs.

To test the location for installation:

Hold the doorbell in the location where you want to install the doorbell, then follow the steps below to test the reception range and video capture angle.

1. Press **MENU** when the handset is idle.
2. Press  or  to scroll to **Settings**, then press **SELECT**.
3. Press  or  to scroll to **Doorbell setup**, then Press **SELECT**.
4. Press  / **DOORBELL** on the doorbell to check the video streaming quality. Press **ISO** on the handset, then press **+** or **-** to adjust the video streaming brightness.
 - If audio feedback occurs, press  on the handset to turn off the speakerphone.
 - If the desired location is in good range, the handset displays .
 - If the desired location is not in good range, the handset flashes  in red. Press **INFO** for instructions to relocate your handset and/or telephone base. When the reception is in good range, the handset displays . Press **OK** to return to the video streaming.
5. Keep the video streaming on for camera lens adjustment.

When finding a desirable location for the doorbell:

- Make sure the visitor is standing a reasonable distance away from the doorbell.
- Avoid mounting it on a location which is subjected to vibration or shock.
- Avoid mounting it on an enclosed area where it may cause echoes.
- Avoid mounting it to where it is exposed to direct sunlight.
- Avoid mounting it to where reflections may be caused by sunlight, for example, opposite to a white wall.

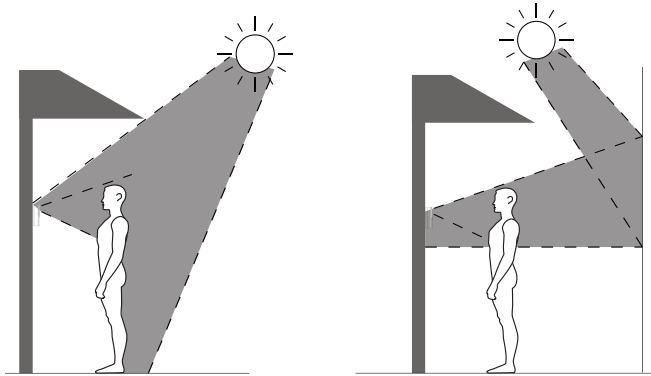

- Two built-in infrared LEDs are for night vision. Make sure the surrounding light source is sufficient for infrared operation.

Test at the front door to determine when the infrared LEDs turn on. When they are in operation, they turn red.

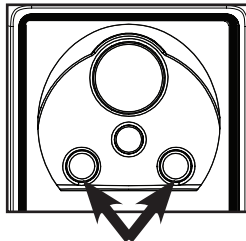

Infrared LEDs

To adjust the shooting area, you may either relocate the doorbell to a different height level, or adjust the camera angle (see below).

To adjust the camera angle:

- Tilt the lever to adjust the angle of the camera lens. The camera lens can be adjusted to left, right or down, up to 10 degrees.

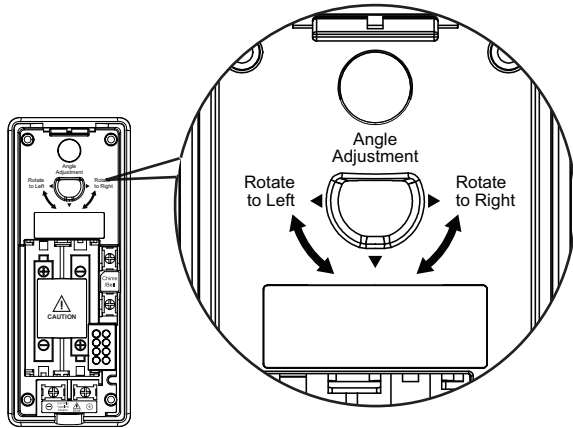

The diagrams below demonstrate an example of doorbell camera position to view a visitor about 50 centimetres from the camera. The camera in this example is set in default angle (0 degree).

You may move the lever at the back of the doorbell to adjust the shooting area (the camera lens).

Side view

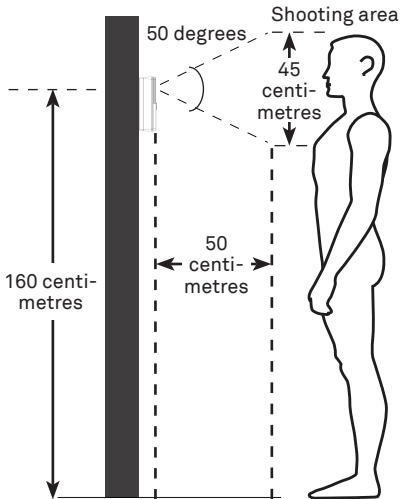

Top view

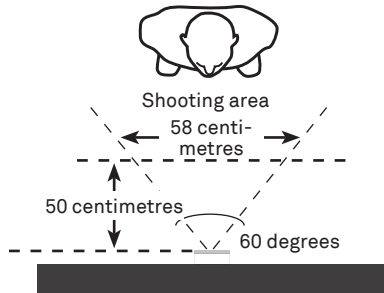

You may install the doorbell in a lower position. The diagram on the next page demonstrates an example of doorbell camera position to view a visitor about 50 centimetres from the camera. The camera in this example is set in 10 degrees angle upward.

Side view

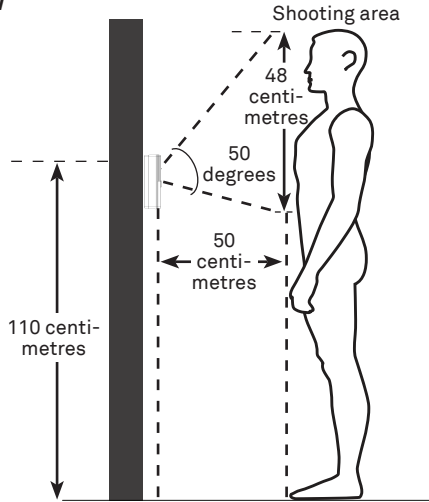

You may install the doorbell on the left or right side. The diagram below demonstrates an example of doorbell camera position to view a visitor about 50 centimetres from the camera. The camera in this example is set in 10 degrees angle to the right.

Top view

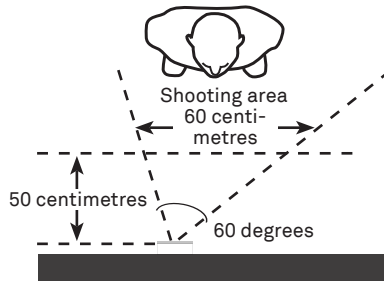

After you have tested the reception range and found the desirable location to install the doorbell, press **END** on the handset to end the video streaming and proceed to **Doorbell installation**.

Doorbell installation

Make sure to test the reception and the doorbell position before you mount the doorbell on the wall.

1. See **Locating the doorbell** on pages 16-20 to choose a desirable position for the doorbell. Use a pencil to mark two holes on the desired location. Then remove the wall mount and drill two holes in the wall. Check for reception strength and camera angle before drilling the holes.

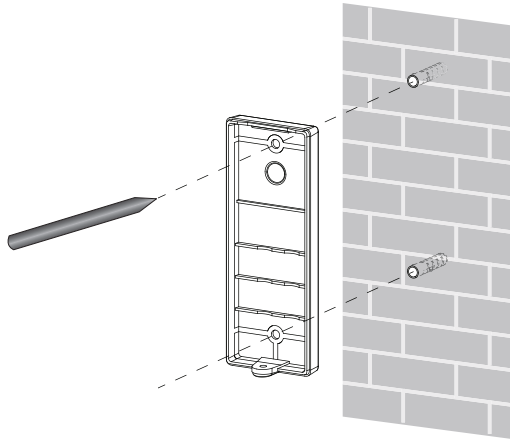

2. If you drill the holes into a stud, go to step 3.

-OR-

If you drill the holes into an object other than a stud, insert the wall anchors into the holes and tap gently on the ends with a hammer until the wall anchors are flush with the wall.

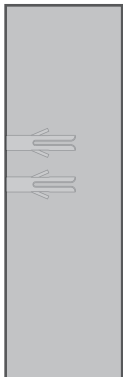

3. Align the holes on the wall mount cover with the holes on the wall (or stud). Tighten the screws into the holes to secure the wall mount cover onto the wall.

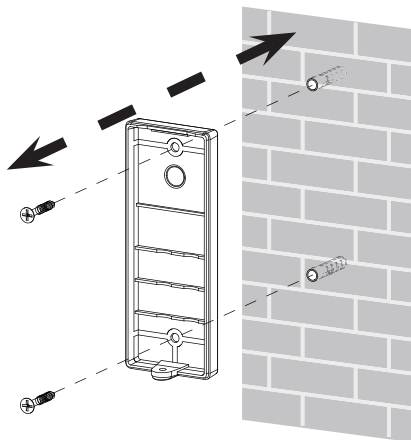

4. Push the doorbell gently onto the wall mount until they are sealed tightly.
This doorbell meets the IPX4 waterproof standard. Make sure the doorbell is tightly sealed with its wall mount cover in order to maintain its waterproof ability.
5. Tighten the screw into the threaded socket at the bottom to secure.

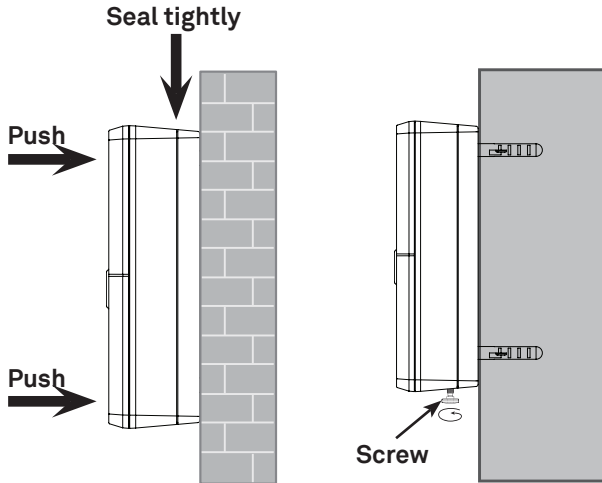

Detach doorbell from wall mount cover

After an extended exposure to cold, heat or humidity, the doorbell gasket rubber may become sticky.

If you need to remove the doorbell from its wall mount cover in case of battery replacement or doorbell relocation, follow the steps below.

1. Remove the screw at the bottom.
2. Insert a flat-bladed screwdriver between the doorbell and its wall mount cover to pry open at both sides.

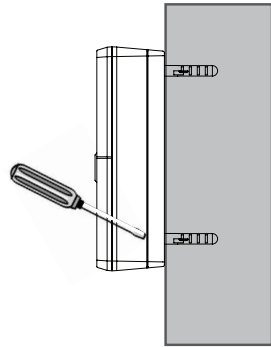
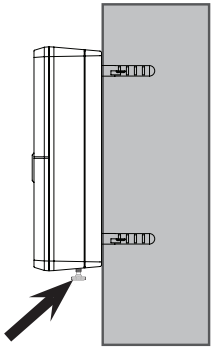

3. Pry the doorbell off.

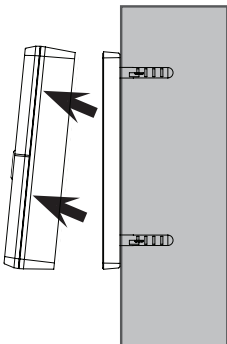

INSTALLATION OPTIONS

Your telephone base is ready for tabletop use. If you want to mount your telephone on a wall, follow the steps below to connect the telephone base with a standard dual-stud telephone wall mounting plate. You may need a professional to install the wall mounting plate.

Tabletop to wall mount installation

1. Unplug the power adaptor from the mains socket. Unplug the telephone line cord (or DSL filter) from the wall socket. Remove the telephone line cord and the power adaptor cord from the slot on the wall mount bracket and unplug them from the telephone base.

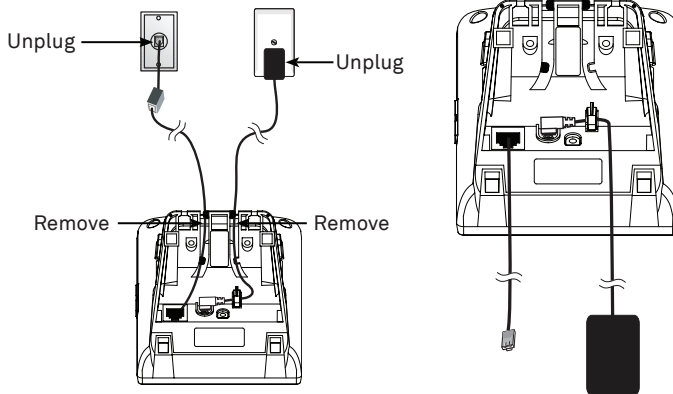

2. Route the telephone line cord through the rectangular hole on the wall mount bracket. Position the lower portion grooves on the telephone base to the lower portion tabs (marked B) on the wall mount bracket. Make sure the upper portion grooves of the telephone base are above the upper portion tabs (marked A) on the wall mount bracket. Push the telephone base down until it clicks securely in place.

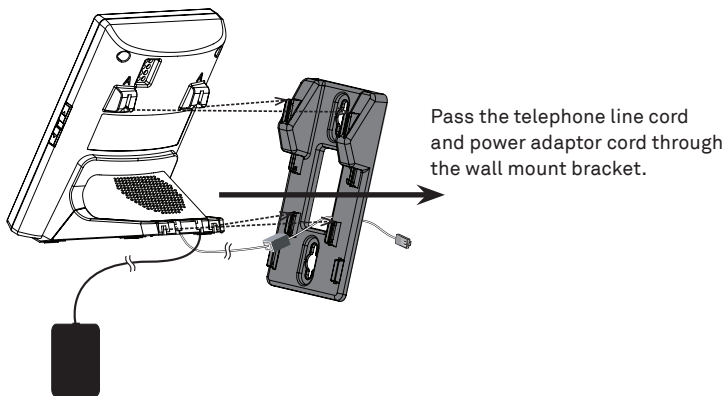

3. Plug the telephone line cord into the telephone wall jack or DSL filter. Align the slots on the bracket with the studs of the wall mounting plate. Slide the bracket down until it locks securely on the wall mounting plate.

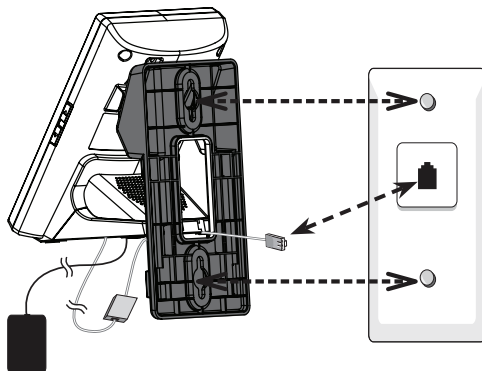

4. Plug the large end of the power adaptor into a mains power wall socket. Bundle the telephone line cord and power adaptor cord neatly with twist ties.

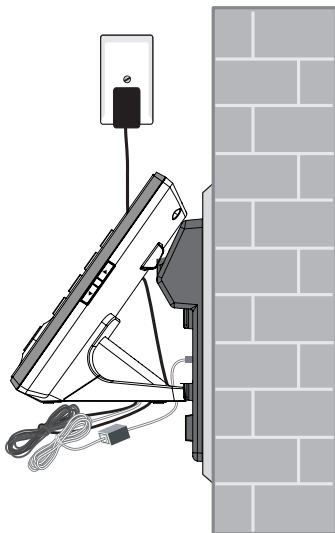

Wall mount to tabletop installation

To change the telephone base from the wall mount position to tabletop position, follow the steps below.

1. If the telephone line cord and power adapter cord are bundled, untie them first.
2. Slide the wall mount bracket up and remove it from the wall plate. Unplug the telephone line cord (or DSL filter) from the wall socket. Unplug the power adapter from the mains socket.
3. Slide the telephone base up and remove it from the wall mount bracket.

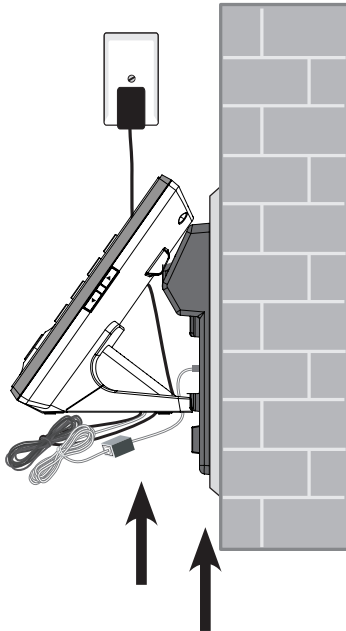

4. See **Telephone base installation** on pages 11-12.

IMPORTANT

Check for a dial tone by pressing . If you hear a dial tone, the installation is successful.

WARNING

Do not place your Telstra 13950 in the bathroom or other humid areas.

IMPORTANT

The base station must be plugged into the mains power socket at all times. Do not connect the telephone line until the handset is fully charged. Only use the power adaptor, telephone cables and NiMH battery supplied with the product.

RE-CHARGEABLE BATTERY LOW WARNING

If the  icon flashes in the handset display, you will need to recharge the handset before you can use it again.

During charging, the  icon will appear to be filling in the display.

RE-CHARGEABLE BATTERY PERFORMANCE

In ideal conditions, the fully charged battery should give up to 10 hours talk time, or 100 hours standby time, on a single charge. Note that a new battery will not reach full capacity until it has been in normal use for several days.

To keep the battery in the best condition, leave the handset off the base for a few hours at a time. Running the battery right down at least once a week will help it last as long as possible. The charge capacity of the rechargeable battery will reduce with time as it wears out, giving the handset less talk / standby time.

Eventually it will need to be replaced. A replacement battery can be obtained by contacting TechHelp on 1300 369 193 or from your local electrical retailer.

After charging your handset for the first time, subsequent charging time is about 6–8 hours a day. The battery and handset may become warm during charging, however, this is normal.

USING YOUR TELTRA 13950 PHONE ON A BROADBAND ADSL LINE?



If this product is to be used on a broadband ADSL line, then you must ensure that it is connected via an ADSL filter. Using this product on a Broadband line without an ADSL filter may cause problems with this product and your Broadband service.

DATE AND TIME

If you have subscribed to Telstra's Calling Number Display service, the date and time are set automatically with each incoming call.

The date and time is recorded with each answering machine message you receive. If you have not subscribed to Telstra's Calling Number Display Service you can set the date and time manually.

Set the date and time manually

1. Press **MENU** when idle.
2. Press  or  to scroll to **Date & Time**, then press **SELECT** on the handset.
3. Enter the date, month and year, then press **SET** on the handset.
4. Enter the hour and minute in 24-hour format.
5. Press **SET** on the handset.

GETTING TO KNOW YOUR PHONE

TELEPHONE BASE BUTTONS

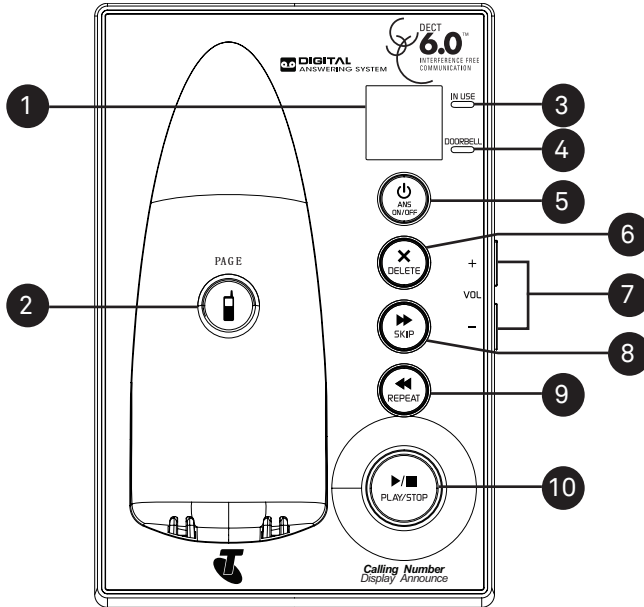

1. MESSAGE WINDOW

- Shows the number of messages, and other information of the answering machine or telephone base.

2. **PAGE**

- Press to page all system handsets.

3. IN USE LIGHT

- Flashes quickly when there is an incoming call.
- Flashes when another telephone sharing the same line is in use.
- On when the telephone line is in use.

4. DOORBELL LIGHT

- On when a doorbell is in a video streaming session.
- Flashes quickly when the doorbell is being pressed.

5. /ANS ON/OFF

- Press to turn the answering machine on or off.

6. /DELETE

- Press to delete the playing message.
- Press twice to delete all old messages when in idle.

7. +/VOL/-

- Press to adjust the listening volume during a call or message playback.
- Press to adjust the telephone base ringer volume when the phone is not in use.

8. /SKIP

- Press to skip to the next message.

9. /REPEAT

- Press to repeat the playing message.
- Press twice to play the previous message.

10. /PLAY/STOP

- Press to play messages.
- Press to stop playing messages.

HANDSET BUTTONS

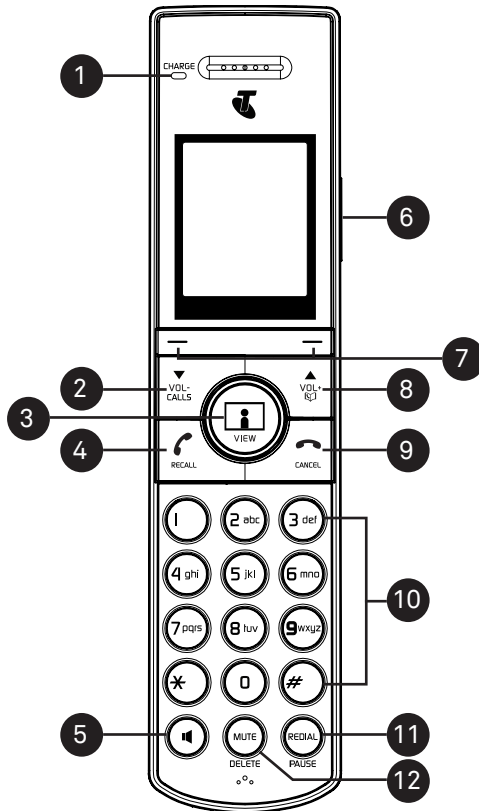

1. CHARGE LIGHT

- On when the handset is charging in the telephone base or charger.

2. /VOL-/CALLS

- Press to scroll down while in a menu, or in the phonebook, call list or redial list.
- Press to review the call list when the phone is not in use.
- While entering names or numbers, press to move the cursor to the left.
- During a call or message playback, press to decrease the listening volume.

3. /VIEW

- When you hear a chime, press to start video streaming.
- Press to extend video streaming session.
- Press to review the photo log when the phone is not in use.

4. /RECALL

- Press to make or answer a call.
- During a call, press to answer an incoming home call when you receive a call waiting alert.

5.

- Press to make or answer a call using the handset speakerphone.
- Press to switch between the handset speakerphone and the handset earpiece during a call.

6. SNAPSHOT

- Press to take a photo shot of visitor from the doorbell during video streaming.

7. SOFTKEYS

- Press to select a menu item displayed above the key.





8. /VOL+/DIR

- Press to scroll up while in a menu, or in the phonebook, call list or redial list.
- Press to review the phonebook when the phone is not in use.
- While entering names or numbers, press to move the cursor to the right.
- During a call or message playback, press to increase the listening volume.

9. /CANCEL

- During a call, press to hang up.
- While in a menu, press to return to the previous menu, or press and hold to return to idle mode, without making changes.
- While the phone is ringing, press to silence the handset ringer temporarily.
- Press and hold to erase the missed call indicator when the phone is not in use.

10. ALPHANUMERIC KEYPAD/* (star)/#(hash)

- Press to enter numbers or characters/*/#.
- Press any key to answer an incoming call.
-  key in idle mode: Press and hold to access Telstra Home Message 101[®] or MessageBank[®].
- Press  to switch between upper case and lower case while entering characters.
- Press and hold  to set and turn on the quiet mode, or turn it off.
- Press and hold  during a call to answer call waiting.
- Press and hold  to start a 3-Way-Chat.

11. /REDIAL/PAUSE

- Press repeatedly to view the last 10 numbers dialed.
- While entering numbers, press and hold to insert a dialing pause.

12. /MUTE/DELETE

- During a call, press to mute the microphone.
- While the phone is ringing, press to silence the handset ringer temporarily.
- While reviewing the redial list, phonebook or call list, press to delete an individual entry.
- While using the dialing keys, press to delete digits, or press and hold to return to idle mode.

DOORBELL BUTTONS

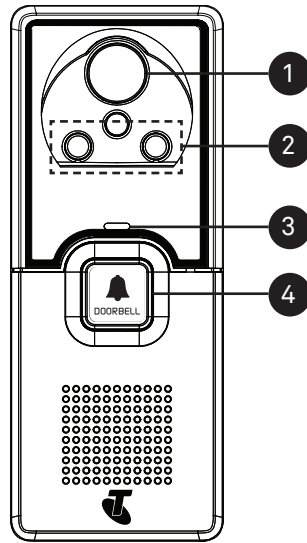

1. CAMERA LENS

2. INFRARED LEDs

- Backup light for night vision.













3. DOORBELL LIGHT

- Flashes when /DOORBELL is pressed.

4. /DOORBELL

- Press to send a chime to the telephone base and capture a photo.





HANDSET AND TELEPHONE BASE DISPLAY

Display icons	Description: Icons can be on (visible), or Flashing or Off (not visible)
	Battery is low; place handset in charger to recharge.
	Full battery power level.
	2/3 battery power level.
	1/3 battery power level.
	High level of video signal reception strength.
	Medium level of video signal reception strength.
	Low level of video signal reception strength.
	The handset speakerphone is in use.
	On if the doorbell is ringing.
	On steadily if the handset ringers are turned off.
	There are new messages recorded by the answering machine.
	There are new voicemail received from the telephone service provider.
MIC OFF	Microphone is muted.
ANS ON	The answering machine is turned on.

NAVIGATING THE MENU

Your Telstra 13950 has an easy to use menu system. Each menu has a list of options, as outlined on the following page.

To enter the main menu of the handset

1. Press **MENU** in idle mode to enter the main menu.
2. Press  or  to select a handset feature menu, then press **SELECT** to enter that menu.
3. Press  to cancel an operation, back up to the previous menu, or exit that menu.
4. To return to idle mode, press and hold .

Note: If no key is pressed within 30 seconds, the telephone automatically returns to idle mode.

HANDSET MENU LAYOUT

Play msgs	AnsweringSys	Phonebook	Caller ID log	Photo log
	Announcement Delete all old Record memo Answer ON/OFF Ans sys setup	Review Add contact Speed dial	Review Del all calls	Doorbell Delete all

Intercom	Ringers	Chime	Date & Time	Setttings
HANDSET All handsets	Ringer volume Ringer tone	Chime volume Chime tone		Rename devices Annc Caller ID LCD brightness Dim mode Wallpaper Clr voicemail Key tone Doorbell setup

KEYSTROKE TABLE

Dialing key	Characters by number of key presses										
	1	2	3	4	5	6	7	8	9	10	11
1	1	.	-	'	()	*	#	&	/	,	
2	a	b	c	A	B	C	2				
3	d	e	f	D	E	F	3				
4	g	h	i	G	H	I	4				
5	j	k	l	J	K	L	5				
6	m	n	o	M	N	O	6				
7	p	q	r	s	P	Q	R	S	7		
8	t	u	v	T	U	V	8				
9	w	x	y	z	W	X	Y	Z	9		
0	Space	0									
*											
#											

Note: When entering a name in the phonebook, the first letter of each word is automatically capitalized.

USING THE DOORBELL

MAKE AND ANSWER A CHIME

To make a chime at the doorbell:

Press /DOORBELL.

To answer a chime on a handset:

Press **SPEAK**.

START A VIDEO STREAMING SESSION

Press /VIEW on a handset when /DOORBELL is pressed and you hear a chime,

Options while video streaming:

- Press the flashing **SPEAK** to talk to the visitor.
- Press **SNAPSHOT** to take a photo shot of the visitor.
- Press **ISO**, then press **+** or **-** to adjust the video stream brightness.

EXTEND A VIDEO STREAMING SESSION

The video/audio streaming session ends in 45 seconds if it is initiated by the doorbell or 60 seconds if initiated by the handset. When the screen displays **Session is ending... Press [VIEW] to extend.** and /VIEW flashes, you have five seconds to extend the video session,



To extend a video streaming session:

Press /VIEW on a handset.

END A VIDEO STREAMING SESSION



Press  on the handset or place the handset in the telephone base or charger.

ANSWER AN INCOMING CALL DURING VIDEO STREAMING

- Press  on the handset to answer the outside call. The video streaming session ends automatically.
- Press  to end the video streaming session without answering the outside call. The video streaming session ends and the telephone continues to ring.

VIEW CAPTURED PHOTOS



The telephone stores up to 100 photos captured by the doorbell.

1. Press /**VIEW** when the handset is not in use, then press **SELECT**.
2. Press  or  to browse through the photo log.

DELETE A CAPTURED PHOTO

When the desired photo displays, press **DELETE**.

DELETE ALL CAPTURED PHOTOS

1. Press /**VIEW** when the handset is not in use
2. Press  or  to scroll to **Delete all**, then press **SELECT**.
3. Press **YES** to confirm.

NIGHT VISION

To help you carry out the video streaming session at night, the doorbell automatically uses the light from its infrared LEDs for transmitting images to the handset unit when the surrounding is dark. However, it only transmits black-and-white images.

USING THE PHONE

MAKE, REDIAL, ANSWER OR END A CALL

To make a call:

Press  or .

When you hear a dial tone, dial the number.

To redial a call:

Enter the telephone number.

Press  or  to dial.

To answer a call:

Press  or  or any dialing key.



To end a call:

Press  or place the handset in the telephone base or charger.

HANDSET SPEAKERPHONE

When the handset is on a call, press  to switch between the speakerphone and the handset earpiece.

VOLUME CONTROL

During a call, press  or .

MUTE

The mute function allows you to hear the other party but the other party cannot hear you.

- During a call, press **MUTE**.
- Press **MUTE** again to resume the conversation.

TEMPORARY RINGER SILENCING

When the telephone is ringing, you can temporarily silence the ringer of the handset or the telephone base without disconnecting the call. The next call rings normally at the preset volume.

To silence the ringer temporary on a handset:

Press  **MUTE** or **SILENCE** on the handset.



To silence the ringer temporary at the telephone base:

Press **VOL-**.





CHAIN DIALING

Use this feature to initiate a dialing sequence from numbers stored in the phonebook, call list or redial list while you are on a call using the handset.



To access a number from the phonebook while on a call:

1. Press **OPTION**.
2. Press **SELECT** to select **Phonebook**.
3. Press  or  to scroll to the desired entry, then press **DIAL** to dial the displayed number.

To access a number from the call list while on a call:

1. Press **OPTION**.
2. Press  or  to scroll to **Caller ID log**, then press **SELECT**.
3. Press  or  to scroll to the desired entry, then press **DIAL** to dial the displayed number.

To access a number from the redial list while on a call:

1. Press **REDIAL** to enter the redial list.
2. Press  or  or **REDIAL** repeatedly to browse to the desired entry.
3. Press **DIAL** to dial the displayed number.

PAGE HANDSET

This feature helps you find misplaced handset(s).



To start the paging tone:

Press /PAGE on the telephone base. All idle handsets ring and their screens display **** Paging ****.

To stop the paging tone:

Press /PAGE on the telephone base.





-OR-

Press    or any dialing key on a handset, or return the handset to the telephone base or charger.

REDIAL

Each handset stores the last 10 telephone numbers dialed (up to 30 digits). When there are already 10 entries, the oldest entry is deleted to make room for the new entry.

To review and dial a redial number:

1. Press **REDIAL** when idle.
2. Press    or **REDIAL** repeatedly to browse until the desired entry displays.
3. Press  or  to dial.

To delete a redial number:

While the handset displays the desired number, press **DELETE** to delete the number from the redial memory.





EQUALIZER

The equalizer enables you to change the quality of the handset audio to best suit your hearing. The default setting is **Natural**.

During a call, press **EQ** repeatedly to select the equalizer setting **Natural**, **Treble 1**, **Treble 2** or **Bass** for the handset.

TRANSFER A CALL

While on an outside call, you can transfer the call from one system device to another. This feature is only applicable to models with more than one handset.

1. During a call, press **OPTION**.
2. Press  or  to scroll to **Transfer**, then press **SELECT**.
 - If your system has more than two handsets, press  or  to scroll to the destination handset or use the dialing keys to enter the destination device number, and then press **SELECT**.

Your handset displays **Transferring call to HANDSET X**, or **Transferring call to all...** if you choose **All handsets**. The destination handset displays **Transfer from other handset** or **Transfer from HANDSET X**. The destination device rings.

3. To answer the call, press  or any dialing key on the destination handset.

JOIN A CALL IN PROGRESS

Another handset can join an outside call. You can share an outside call with up to four handsets at the same time.

To join a call:

- Press  or  to join the call.
- Press  or place the handset in the telephone base or charger to exit the call.



INTERCOM

Use the intercom feature for conversations between two system devices. This feature is only applicable to models with more than one handset.



1. Press **INTCOM** when idle.

-OR-

Press **MENU**, press  or  to scroll to **Intercom**, then press **SELECT**.



- If your system has more than two handsets, press  or  to scroll to the destination handset or use the dialing keys to enter the destination device number, and then press **SELECT**.

Your handset displays **Calling HANDSET X**, or **Calling all handsets** if you choose **All handsets**. The destination handset displays **Other handset is calling** or **HANDSET X is calling**. The destination device rings.

2. To answer the intercom call, press  or any dialing key on the destination handset.
3. To end the intercom call on either handset, press  or **END** on the handset or place the handset back in the telephone base or charger.

ANSWER AN INCOMING CALL DURING AN INTERCOM CALL





If you receive an outside call during an intercom call, there is an alert tone.

To answer the call, press  or  on the handset. The intercom call ends automatically.

To end the intercom call without answering the outside call, press  on the handset. The intercom call ends and the telephone continues to ring.





CALL TRANSFER USING INTERCOM

Use the intercom feature to transfer an outside call from one handset to another.

1. During a call, press **OPTION**.
2. Press  or  to scroll to **Intercom**, then press **SELECT**.
 - If your system has more than two handsets, press  or  to scroll to the destination handset or use the dialing keys to enter the destination device number, and then press **SELECT**.

Your handset displays **Calling HANDSET X**, or **Calling all handsets** if you choose **All handsets**. The destination handset displays **Other handset is calling** or **HANDSET X is calling**. The destination device rings.





3. To answer the call, press  or any dialing key on the destination handset. The outside call is now on hold and both system devices display Intercom. You can have a private conversation with the destination device.

4. From this intercom call, you have the following options:
- You can let the destination handset join you on the outside call in a three-way conversation. Press **OPTION**. Press  or  to scroll to **Share call** on your handset, then press **SELECT**.
 - You can transfer the call. Press **OPTION**, then press **SELECT** to choose **Transfer**. The destination system device automatically connects to the outside call.
 - Either person can press  or  on the handset to take the held outside call, or press  or **END** on the handset to end the intercom call. The outside call continues until both devices hang up.



PHONEBOOK

The phonebook stores up to 50 entries with up to 30 digits for each phone number and 15 characters for each name, which are shared by all devices.

ADD A PHONEBOOK ENTRY

1. Press **MENU** when idle.
2. Press  or  to scroll to **Phonebook**, then press **SELECT**.
3. Press  or  to scroll to **Add contact**, then **SELECT**.
4. Enter a number.



-OR-

Copy a number from the redial list by pressing **REDIAL** then  or , or pressing **REDIAL** repeatedly to find the desired number. Press **INSERT** to copy the number.





5. Press **NEXT**.
6. Enter a name, then press **SAVE**.

REVIEW PHONEBOOK ENTRIES



Phonebook entries appear alphabetically.

1. Press  on the handset when idle to show the first entry in the phonebook.
2. Press  or  to browse through the entries.

ALPHABETICAL SEARCH

1. Press  on the handset when idle to show the first entry in the phonebook.
2. Use the dialing keys to enter the letter associated with the name. For example, if you have the entries named Jennifer, Jessie, Kevin and Linda in your phonebook, press  once to see Jennifer (when Jennifer displays, press  to see Jessie), twice to see Kevin, or three times to see Linda. If necessary, press  or  to browse.

DIAL A PHONEBOOK ENTRY

1. Search for the desired entry in the phonebook (see **Review phonebook entries** or **Alphabetical search** on page 49).
2. To dial the displayed entry on the handset, press  or .

EDIT A PHONEBOOK ENTRY

1. Search for the desired entry in the phonebook (see **Review phonebook entries** or **Alphabetical search** on page 49). Press **EDIT**.
2. Edit the number, then press **NEXT**.
3. Edit the name, then press **SAVE**.

DELETE A PHONEBOOK ENTRY

1. Search for the desired entry in the phonebook (see **Review phonebook entries** or **Alphabetical search** on page 49).
2. To delete the displayed phonebook entry, press **DELETE**. Then press **YES** to confirm. You cannot retrieve a deleted entry.







SPEED DIAL

The telephone system has nine speed dial locations (2-9, 0), where you can store the telephone numbers you wish to dial more quickly. You must set the speed dial numbers to the corresponding locations before using them.







The speed dial entries are shared by all devices. Changes made to the speed dial entries on one handset apply to all devices.

We recommend you store two contacts that you may need to call more often to keys 2 and 3.







ASSIGN A SPEED DIAL ENTRY

1. Press **MENU** when idle.
2. Press  VOL- CALLS or  VOL+ REC to scroll to **Phonebook**, press **SELECT**.
3. Press  VOL- CALLS or  VOL+ REC to scroll to **Speed dial**, press **SELECT**.
4. Press  VOL- CALLS or  VOL+ REC to scroll to the desired speed dial location, then press **ASSIGN**.
5. Search for the desired entry in the phonebook (see **Review phonebook entries** or **Alphabetical search** on page 49).
6. Press **ASSIGN** to save.

REASSIGN A SPEED DIAL ENTRY

1. Press **MENU** when idle.
2. Press  VOL- CALLS or  VOL+ REC to scroll to **Phonebook**, press **SELECT**.
3. Press  VOL- CALLS or  VOL+ REC to scroll to **Speed dial**, press **SELECT**.
4. Press  VOL- CALLS or  VOL+ REC to scroll to the desired speed dial location, then press **VIEW**.
5. Search for the desired entry in the phonebook (see **Review phonebook entries** or **Alphabetical search** on page 49).
6. Press **REPLACE**, then **YES** to confirm.

DELETE A SPEED DIAL ENTRY

1. Press **MENU** when idle.
2. Press  or  to scroll to **Phonebook**, press **SELECT**.
3. Press  or  to scroll to **Speed dial**, press **SELECT**.
4. Press  or  to scroll to the desired speed dial location.
5. Press **DELETE**, then **YES** to confirm.





DIAL A SPEED DIAL NUMBER

- When the phone is idle, press and hold a dialing key to dial the number stored in the corresponding speed dial location.

PHONE SETTINGS

USING THE MENU

You can use the menu of a handset to change the telephone settings.





1. Press **MENU** when idle.
2. Press  or  until the screen displays the desired feature menu.
3. Press **SELECT** to enter that menu.
 - To return to the previous menu, press .
 - To return to idle mode, press and hold .

RINGER VOLUME







Telephone base ringer volume:

- Press **+VOL** or **VOL-** when idle.







Handset ringer volume:

1. Press **MENU** when idle.
2. Press  or  to scroll to **Ringers**, press **SELECT**.
3. Press **SELECT** to select **Ringer volume**.
4. Press  or  to sample each volume level, or press **OFF** to turn off the ringer.
5. Press **SET** to save.









RINGER TONE

1. Press **MENU** when idle.
2. Press  or  to scroll to **Ringers**, then press **SELECT**.
3. Press  or  to scroll to **Ringer tone**, then press **SELECT**.
4. Press  or  to sample each ringer tone.
5. Press **SELECT** to save.

CHIME VOLUME

1. Press **MENU** when idle.
2. Press  VOL-CALLS or  VOL-SET to scroll to **Chime**, press **SELECT**.
3. Press **SELECT** to select **Chime volume**.
4. Press  VOL-CALLS or  VOL-SET to select **Local handset** or **Base**, then press **SELECT**.
5. Press  VOL-CALLS or  VOL-SET to sample each volume level, or press **OFF** to turn off the chime.
6. Press **SET** to save.

CHIME TONE

1. Press **MENU** when idle.
2. Press  VOL-CALLS or  VOL-SET to scroll to **Chime**, then press **SELECT**.
3. Press  VOL-CALLS or  VOL-SET to scroll to **Chime tone**, then press **SELECT**.
4. Press  VOL-CALLS or  VOL-SET to select **Local handset** or **Base**, then press **SELECT**.
5. Press  VOL-CALLS or  VOL-SET to sample each chime tone.
6. Press **SET** to save.

QUIET MODE

You can turn on the quiet mode for a period of time (1-12 hours). During this period, all tones (except paging tone and chime), and call screening are muted.

When you turn on the quiet mode, the answering machine turns on automatically.

When the quiet mode duration expires, the answering machine remains on.

To set and turn the quiet mode on:



1. Press and hold  when idle. The screen shows **SET QUIET MODE DURATION (1 to 12 hours)**.
2. Enter the desired duration (1-12), then press **SET** to confirm.

To turn the quiet mode off:

- While the quiet mode is on, press and hold  when idle.









SET DATE AND TIME

The answering machine announces the date and time of each message prior to playing it. Before using the answering machine, set the date and time as follows. If you subscribe to a Calling Number Display service, the day, month and time are set automatically with each incoming call.

1. Press **MENU** when idle.
2. Press  VOL- CALLS or  VOL+ SET to scroll to **Date & Time**, then press **SELECT**.
3. Enter the date, month and year, then press **SET**.
4. Enter the hour and minute in 24-hour format.
5. Press **SET** to save.





CALLING NUMBER DISPLAY VOICE ANNOUNCE[®]

The voice announce feature lets you know who's calling without having to look at the display.

1. Press **MENU** when idle.
2. Press  VOL- CALLS or  VOL+ SET to scroll to **Settings**, then press **SELECT**.
3. Press  VOL- CALLS or  VOL+ SET to scroll to **Annc Caller ID**, then press **SELECT**.
4. Press  VOL- CALLS or  VOL+ SET to scroll to the desired option, then press **SELECT**.
 - **Set all On/Off** - Change the setting for all devices.
 - **Local handset** - Change the setting for that handset only.
 - **Base** - Change the setting for the telephone base only.
4. Press  VOL- CALLS or  VOL+ SET to select **On** or **Off**, then press **SET** to save.







CLEAR VOICEMAIL INDICATORS

Use this feature when the telephone indicates that there is new voicemail but there are none. This feature only turns off the indicators, New voicemail and . It does not delete your voicemail messages. As long as you have new voicemail messages, your telephone service provider continues to send the signal to turn on the indicators.

1. Press **MENU** when idle.
2. Press  VOL- or  VOL+ to scroll to **Settings**, then press **SELECT**.
3. Press  VOL- or  VOL+ to scroll to **Clr voicemail**, then press **SELECT**.
4. Press **YES** to confirm.







RENAME BASE/HANDSET

You can create a name for each system handset and the telephone base.

1. Press **MENU** when idle.
2. Press  VOL- or  VOL+ to scroll to **Settings**, then press **SELECT**.
3. Press  VOL- or  VOL+ to scroll to **Rename devices**, then press **SELECT**.
4. Press  VOL- or  VOL+ to select **Local handset** or **Doorbell**, then press **SELECT**.
5. Enter the desired name, then press **SAVE**.





KEY TONE



The handset is set to beep with each key press. You can set the key tone volume or turn the key tone off for each handset.

1. Press **MENU** when idle.
2. Press  VOL- or  VOL+ to scroll to **Settings**, then press **SELECT**.
3. Press  VOL- or  VOL+ to scroll to **Key tone**, then press **SELECT**.
4. Press  VOL- or  VOL+ to sample each volume level.
5. Press **SET** to save.

LCD BRIGHTNESS







You can adjust the screen brightness of your handset to optimize readability lighting conditions.

1. Press **MENU** when idle.
2. Press  VOL- or  VOL+ to scroll to **Settings**, then press **SELECT**.
3. Press  VOL- or  VOL+ to scroll to **LCD brightness**, then press **SELECT**.

4. Press  or  to sample each brightness level.
5. Press **SET** to save.







DIM MODE

You can set the handset backlight in dim mode or completely off when idle.

1. Press **MENU** when idle.
2. Press  or  to scroll to **Settings**, then press **SELECT**.
3. Press  or  to scroll to **Dim mode**, then press **SELECT**.
4. Press  or  to select **On** or **Off**, then press **SET** to save.

WALLPAPER

You can set the wallpaper for your handset.

1. Press **MENU** when idle.
2. Press  or  to scroll to **Settings**, then press **SELECT**.
3. Press  or  to scroll to **Wallpaper**, then press **SELECT**.
4. Press  or  to sample each wallpaper.
5. Press **SET** to save.

TELSTRA NETWORK SERVICES*

*Subscription and/or usage charges may apply to use these services. Call 13 22 00 or visit telstra.com/homephone for more information.

CALLING NUMBER DISPLAY

If you have subscribed to Telstra's Calling Number Display service, you will be able to see your caller's number on your handset display (provided it is not blocked) prior to answering the call. If your caller's name is stored in the phonebook and a number match is found, you will see the caller's name on the display instead.

Calling Number Display from the home line allows you to see the name, number, date and time of the incoming calls. The calling number display may appear differently if the caller is matched to a phonebook entry (see **Memory match** on page 59).

When Telstra's Calling Number Display is active on your service, incoming numbers will be saved in the telephone's call list. Your phone can store the date/time information for up to 30 answered or unanswered calls in the call log. The number will be shown on the display when the phone is ringing. If the number matches with one of the entries in your phonebook, the caller's name stored in the phonebook will be displayed with the number. The phone deletes the oldest entry when the log is full to make room for new calls. This information is common to the telephone base and all handsets, so changes made using any handset are reflected in all other handsets. If you answer a call before the information appears on the screen, it does not show in the call list history.

Note: If the phone number has more than 24 digits, only the last 24 digits will be saved or shown in the call list.

Missed calls are marked with **XX Missed calls**. Each time you review a call list entry marked with **NEW**, the number of missed calls decreases by one. When you have reviewed all the missed calls, the missed calls indicator no longer shows. You can review, redial, and copy an entry into the phonebook. Entries appear in reverse chronological order. Only one handset can review the call list at a time. If a handset tries to enter the call list while another handset is already in it, **Not available at this time** appears. The call list information might not be available for every incoming call. The callers might intentionally block their names and/or telephone numbers.

MEMORY MATCH

If the incoming telephone number matches the exact telephone number in your phonebook, including the area code, the name that appears on the screen matches the corresponding name in your phonebook.

For example, if Christine Smith calls, her name appears as Chris if this is how you entered it into your phonebook.

Note: The number you see on your calling number display is in the format sent by the telephone service provider. It usually delivers 10-digit telephone numbers (area code plus telephone number).

CALL LIST DISPLAY SCREEN MESSAGE

With some incoming calls, if the telephone number is not available, the handset may display one of the following explanations:

UNAVAILABLE	This caller's number is unavailable.
PRIVATE	The caller is blocking the telephone number.

When the list is full, and a new call is received, the oldest entry will be deleted automatically.

IMPORTANT

To use Telstra's Calling Number Display you must first subscribe to the service from Telstra. For more information on Telstra Network Services call Telstra on 13 22 00. To ensure the caller's name is displayed, make sure you have stored the telephone number in the phonebook.

MISSED CALL INDICATOR

When there are calls that have not been reviewed in the call list, the screens display **XX Missed calls**. When you have reviewed all the missed calls, the missed call indicator goes away.

Each time you review a call list entry marked **NEW** on the handset, the number of missed calls decreases by one.



If you do not want to review the missed calls one by one, press and hold  on the handset when not in use to clear the missed call indicator. All the entries are then considered old and kept in the call list.

REVIEW THE CALL LIST

Review the call list to find out who called, to return the call, or to copy the caller's name and number into your phonebook.

1. Press  when idle.
2. Press  or  to browse.

DIAL A CALL LIST ENTRY

1. Search for the desired call list entry (see **Review the call list** above).
2. Press  or  on a handset to dial.

SAVE A CALL LIST ENTRY TO THE PHONEBOOK

1. Search for the desired call list entry (see **Review the call list** above).
2. Press **SAVE** to choose the entry.









3. Edit the number, then press **NEXT**.
4. Edit the name, then press **SAVE**.

DELETE CALL LIST ENTRIES



To delete one entry:

1. Search for the desired call list entry (see **Review the call list** on page 60).
2. Press **DELETE** to delete the entry.

To delete all entries:

1. Press **MENU** when idle.
2. Press  **VOL-**  **CALLS** or  **VOL-**  **DEL** to scroll to **Caller ID log**, then press **SELECT**.
3. Press  **VOL-**  **CALLS** or  **VOL-**  **DEL** to scroll to **Del all calls**, then press **SELECT**.
4. Press **YES** to confirm.





FLASHING MESSAGE INDICATOR (FMI)

The Telstra 13950 is designed to provide visual indication when a new message is left in your Telstra Home Messages 101[®] or MessageBank[®] service. To arrange connection of the Flashing Message Indicator service, simply call Telstra on 13 22 00. When a new message is left, New voicemail the  icon will be displayed on the handsets. After you have listened to your message(s), the  icon will disappear and the indicators on the handsets turn off automatically.

Reset the voicemail indicators when the telephone indicates that there is new voicemail but there is none (for example, when you have accessed your voicemail while away from home). Clearing the voicemail waiting indicators only turns off the indicators; it does not delete your voicemail messages. As long as you have new voicemail messages, your telephone service provider continues to send the signal to turn on the indicators.

To reset the voicemail indicator:

1. Press **MENU** when idle to enter the main menu.

2. Press  or  to scroll to **Settings**, then press **SELECT**.
3. Press  or  to scroll to **Clr voicemail**, then press **SELECT**.
4. The screen displays **Reset Voicemail Indication?**, then press **YES**.

Notes:

- Your telephone service provider might alert you to new voicemail messages with a stutter (broken) dial tone. Contact your telephone service provider for more details.
- For more information about the difference between your answering machine and voicemail, see page 68.

TELSTRA HOME MESSAGES 101[®] OR MESSAGEBANK[®]



You can get messages from your Telstra fixed home phone when you are away from the phone, busy on another call or using the Internet. Callers will hear a standard greeting inviting them to leave a message.

To call Telstra Home Messages 101[®] or MessageBank[®]

While the handset is in idle mode, press and hold . The handset will dial 125101.

CALL WAITING



Call Waiting tells you if a new caller is trying to contact you when you are already on the phone. A network tone alerts you to the new caller, so you can answer your second incoming call by putting the first caller on hold.

1. Press and hold  on the handset. Your first caller is put on hold and you can talk to your second caller.
2. To revert back to the original caller, Press and hold  again.

3-WAY CHAT

This service is available on most lines ready for you to use. If you are already on a call, you can add another person and then have a 3-Way Chat.

To put existing call on hold and make a new call then to 3-Way Chat

1. Press  on the handset you are currently using.
2. Dial the second phone number.
3. Press and hold  on the handset to connect the 3-Way Chat after the second call answered.

To Split a 3-Way Chat or switch between callers

- Press and hold .

ANSWERING MACHINE

The answering machine can record and store up to 99 messages. Each message can be up to 3 minutes in length depending on the message length set (see **Message recording time** on page 67). The total storage capacity for the outgoing message, messages and memos is 15 minutes. The actual recording time depends on individual message characteristics. Messages remain available for replay until you delete them.

Note: Your answering machine will answer calls after 14 rings even when it is turned off. This allows the remote access feature to work.



ANNOUNCEMENT

The telephone is preset with a greeting that answers calls with, “**Hello. Please leave a message after the tone.**” You can use this preset announcement, or replace it with your own.



RECORD YOUR OWN ANNOUNCEMENT

You can record an announcement up to 90 seconds, but any announcement shorter than two seconds will not be recorded.



To record an announcement:

1. Press **MENU** when idle.
2. Press  VOL- CALLS or  VOL+ REC to scroll to **AnsweringSys**, then press **SELECT**.
3. Press **SELECT** again to select **Announcement**.
4. Press **RECORD** to select record an announcement. The system announces, “**Record after the tone. Press STOP when you are done.**” After the tone, speak towards the microphone.
5. Press **STOP** when done.

PLAY YOUR ANNOUNCEMENT

1. Press **MENU** when idle.
2. Press  VOL- CALLS or  VOL+ RE1 to scroll to **AnsweringSys**, then press **SELECT**.
3. Press **SELECT** again to select **Announcement**.
4. Press **PLAY** to play the current announcement.

DELETE YOUR ANNOUNCEMENT







1. Press **MENU** when idle.
2. Press  VOL- CALLS or  VOL+ RE1 to scroll to **AnsweringSys**, then press **SELECT**.
3. Press **SELECT** again to select **Announcement**.
4. Press **PLAY**, and then press **RESET** or **DELETE** to delete your recorded announcement.
5. Press **YES** to confirm. The announcement resets to the preset announcement.

ANSWER ON/OFF

The answering machine must be turned on to answer and record messages.

When the answering machine is turned on, the /ANS ON/OFF light on the telephone base turns on and **ANS ON** displays on the handsets.

To set answer on/off with a handset:

1. Press **MENU** when idle.
2. Press  VOL- CALLS or  VOL+ RE1 to scroll to **AnsweringSys**, then press **SELECT**.
3. Press  VOL- CALLS or  VOL+ RE1 to scroll to **Answer ON/OFF**, then press **SELECT**.
4. Press  VOL- CALLS or  VOL+ RE1 to scroll to **On** or **Off**, then press **SET**.







To set answer on/off with the telephone base:

- Press /ANS ON/OFF to turn the answering machine on or off.

CALL SCREENING

Use this feature to choose whether incoming messages can be heard over the handset or the telephone base while they are being recorded.









To set call screening on/off:

1. Press **MENU** when idle.
2. Press  or  to scroll to **AnsweringSys**, then press **SELECT**.
3. Press  or  to scroll to **Ans sys setup**, then press **SELECT**.
4. Press **SELECT** again to select **Call screening**.
5. Press  or  to scroll to **On** or **Off**, then press **SET**.

NUMBER OF RINGS

You can set the answering machine to answer an incoming call after two, three, four, five or six rings; or toll saver. With toll saver selected, the answering machine answers after two rings if you have new messages, or after four rings if there are no new messages. This enables you to check for new messages and avoid paying long distance charges when calling from out of your local area.







To set number of rings:

1. Press **MENU** when idle.
2. Press  or  to scroll to **AnsweringSys**, then press **SELECT**.
3. Press  or  to scroll to **Ans sys setup**, then press **SELECT**.
4. Press  or  to scroll to **# of rings**, then press **SELECT**.
5. Press  or  to scroll to select **6**, **5**, **4**, **3**, **2** or **Toll saver**, then press **SET**.

REMOTE ACCESS CODE

A two-digit security code is required to access the answering machine remotely from any touch-tone telephone. The preset code is **00**. You can set the code from 00 to 99.









To set remote access code:

1. Press **MENU** when idle.
2. Press  or  to scroll to **AnsweringSys**, then press **SELECT**.
3. Press  or  to scroll to **Ans sys setup**, then press **SELECT**.
4. Press  or  to scroll to **Remote code**, then press **SELECT**.
5. Enter a two-digit number, then press **SAVE**.

MESSAGE ALERT TONE

When the message alert tone is set to on, and there is at least one new message, the telephone base beeps every 10 seconds. There is no audible alert at the handset. The message alert tone is preset to off.









To set message alert tone:

1. Press **MENU** when idle.
2. Press  or  to scroll to **AnsweringSys**, then press **SELECT**.
3. Press  or  to scroll to **Ans sys setup**, then press **SELECT**.
4. Press  or  to scroll to **Msg alert tone**, then press **SELECT**.
5. Press  or  to scroll to **On** or **Off**, then press **SET**.

MESSAGE RECORDING TIME



You can set the recording time allowed for incoming messages. The message length is preset to three minutes.

To set message recording time:

1. Press **MENU** when idle.
2. Press  or  to scroll to **AnsweringSys**, then press **SELECT**.
3. Press  or  to scroll to **Ans sys setup**, then press **SELECT**.
4. Press  or  to scroll to **Recording time**, then press **SELECT**.
5. Press  or  to scroll to **3 minutes**, **2 minutes** or **1 minute**, then press **SET**.

ANSWERING MACHINE AND VOICEMAIL

Your telephone has separate indicators for two different types of voice messages: those left on its built-in digital answering machine and those left with your telephone service provider's voicemail (fees may apply). Your telephone's built-in digital answering machine messages and voicemail messages are separate. Each alerts you to new messages differently.

- If **XX new msgs** displays on the handset and the message window on the telephone base flashes, there are new messages in the built-in answering machine. To listen to the messages recorded on your digital answering machine, press ►/■/PLAY/STOP on the telephone base.
- If  and **New voicemail** display on the handset, your telephone service provider is indicating that it has new voicemail for you. To listen to your voicemail, press and hold  on your handset.

Some telephone service providers bundle or combine multiple services like voicemail and call waiting, so you may not be aware that you have voicemail. To check what services you have and how to access them, contact your telephone service provider.

To use your voicemail service rather than your answering machine, turn off your answering machine. To use your answering machine rather than your voicemail service, contact your telephone service provider to deactivate your voicemail service.

Using the answering machine and voicemail together:

You can also use your telephone answering machine and voicemail together by setting your built-in answering machine to answer before voicemail answers as described below. To learn how to program your voicemail settings, contact your telephone service provider. Then, if you are on a call, or if the answering machine is busy recording a message and you receive another call, the second caller can leave a voicemail message.

Set your answering machine to answer calls at least two rings earlier than your voicemail is set to answer. For example, if your voicemail answers after six rings, set your answering machine to answer after four rings. Some voicemail providers may program the delay before answering calls in seconds instead of rings. In this case, allow six seconds per ring when determining the appropriate setting.

MESSAGE CAPACITY

The answering machine can record and store up to 99 messages. Each message can be up to three minutes in length, depending on the recording time set. The total storage capacity for the announcement, messages, memos is approximately 15 minutes. The actual recording time depends on individual message characteristics. Messages remain available for replay until you delete them.

When **F** and the number of messages are flashing alternately on the message window and the handsets display **Rec mem full**, the memory is full. You cannot turn on the answering machine and record new messages until some old messages have been deleted.

NEW MESSAGE INDICATION

The message window on the telephone base flashes and **XX new msgs** displays on the handset when there are new answering machine messages.

If the message alert tone is turned on, the telephone base beeps every 10 seconds when there are messages that have not been reviewed.

CALL SCREENING

To screen a call at the telephone base:

If the answering **machine** and call screening are on, the announcement and the incoming message broadcast at the telephone base while the call is answered by the answering machine.

Options while a message is being recorded:

- Press **+VOL** or **VOL-** to adjust the call screening volume.

- Press **+VOL** to temporarily turn on the call screening if it is set to off.
- Press **▶/■/PLAY/STOP** to temporarily turn on or off the call screening.

To screen a call at a handset:

If the answering machine is on and recording a message, press **SCREEN** to screen the call on your handset and the screen displays the caller ID information. If you do not subscribe to caller ID service, the handset shows **Incoming call**.

Options while a message is being recorded:

- Press **VOL+/VOL-** to adjust the call screening volume.
- Press **🔊** to switch between the speakerphone and the handset earpiece.

CALL INTERCEPT

If you want to talk to the caller whose message is being recorded, press **📞** or **🔊** on a handset.

TEMPORARILY TURN OFF THE MESSAGE ALERT TONE

If the message alert tone is turned on, the telephone base beeps every 10 seconds when there are new messages. Pressing any telephone base key (except **📄/PAGE**) temporarily silences the message alert tone.

If you press **X/DELETE** when in idle mode to temporarily turn off the message alert tone, there is a voice prompt directing you to press **X/DELETE** again to delete all old messages. The message alert tone is temporarily off. Only press **X/DELETE** a second time if you wish to erase all old messages in your answering machine.

The message alert tone resumes when you receive a new message.

MESSAGE PLAYBACK

To play messages at the telephone base:

1. Press **▶/■/PLAY** when idle.



Options during playback:

- Press **+VOL** or **VOL-** to adjust the message playback volume.
- Press **▶▶/SKIP** to skip to the next message.
- Press **◀◀/REPEAT** to repeat the message. Press **◀◀/REPEAT** twice to listen to the previous message.
- Press **X/DELETE** to delete the playing message.
- Press **▶/■/STOP** to stop the playback.



To play messages on a handset:

1. Press **MENU** when idle.
2. Press **SELECT** to select **Play msgs**.
3. If you have only new or old messages, the messages play automatically.

-OR-

If you have both new and old messages, press  or  to choose **Play new msgs** or **Play old msgs**, then press **SELECT**.

Options during playback:

1. Press **VOL+/VOL-** to adjust the message playback volume.
2. Press **SKIP** to skip to the next message.
3. Press **REPEAT** to repeat the message. Press **REPEAT** twice to hear the previous message.
4. Press  to switch between speakerphone and handset earpiece.
5. Press **DELETE** to delete the playing message.
6. Press  to stop the playback.





DELETE ALL OLD MESSAGES

You can only delete old (reviewed) messages. You cannot delete new messages until you review them. You cannot retrieve deleted messages.

To delete all old messages with the telephone base:

1. Press **X/DELETE** twice when idle.





To delete all old messages with a handset:

1. Press **MENU** when idle.
2. Press  VOL- CALLS or  VOL+ RE1 to scroll to **AnsweringSys**, then press **SELECT**.
3. Press  VOL- CALLS or  VOL+ RE1 to scroll to **Delete all old**, then press **SELECT**.
4. Press **YES** to confirm.

RECORD, PLAY AND DELETE MEMOS

Memos are your own recorded messages used as reminders for yourself or others using the same answering machine. You can record your own memos using the handset. Play and delete them in the same way as incoming messages.

To record a memo:

1. Press **MENU** when idle.
2. Press  VOL- CALLS or  VOL+ RE1 to scroll to **AnsweringSys**, then press **SELECT**.
3. Press  VOL- CALLS or  VOL+ RE1 to scroll to **Record memo**, then press **SELECT**.
4. The system announces, “**Record after the tone. Press STOP when you are done.**” After the tone, speak towards the microphone.
5. Press **STOP** when done.

REMOTE ACCESS

A two-digit security code is required to access the answering machine remotely from any touch-tone telephone. The preset code is **00**.

1. Dial your telephone number from any touch-tone telephone.
2. When the system plays your announcement, enter the two-digit security code.
3. You can enter one of the following remote commands.

Command	Function
1	Play all messages.
2	Play new messages.
3	Delete the current message (during playback).
33	Delete all old messages.
4	Repeat the current message (during playback).
5	Stop.
*5	Hear a list of remote commands.
6	Skip to the next message (during playback).
*7	Record a new announcement.
8	End the call.
0	Turn the answering machine on or off.

HELP

My telephone doesn't work at all.

- Make sure the power cord is securely plugged in.
- Make sure you plug the battery connector securely into the cordless handset.
- Make sure you plug the telephone line cord securely and firmly into the telephone base and the telephone wall jack.
- Charge the battery in the cordless handset for at least 11 hours. For optimum daily performance, return the cordless handset to the handset charger when not in use.
- If the battery is completely depleted, charge the handset for at least 30 minutes before use.
- Reset the telephone base. Unplug the electrical power. Wait for approximately 15 seconds, then plug it back in. Allow up to one minute for the cordless handset, pendant and telephone base to reset.
- You may need to purchase a new handset battery.
- Disconnect the telephone base from the telephone wall jack and plug in a working telephone. If the other telephone does not work, the problem is probably in the wiring or telephone service. Contact your telephone service provider.

I cannot get a dial tone.

- Try all the suggestions above.
- Move the cordless handset closer to the telephone base. You may have moved out of range.
- If the previous suggestions do not work, disconnect the telephone base from the telephone jack and connect to a different phone. If there is no dial tone on that phone either, the problem is in your wiring or telephone service. Contact your telephone service provider.
- Your line cord may be defective. Try installing a new line cord.

I cannot dial out.

- Try all the suggestions above.
- Make sure you have a dial tone before dialing. The cordless handset may take a second or two to find the telephone base and produce a dial tone. This is normal. Wait an extra second before dialing.
- Eliminate any background noise. Noise from a television, radio or other appliances might cause the phone to not dial out properly. If you cannot eliminate the background noise, first try muting the cordless handset before dialing, or dialing from another room with less background noise.
- If other phones in your home are having the same problem, contact your telephone service provider (charges may apply).
- If you have changed your telephone service to digital service from a cable company or a VoIP service provider, the telephone line may need to be rewired to allow all existing telephone jacks to work. Contact your service provider for more information.

My cordless handset isn't performing normally.

- Make sure you plug the power cord securely into the telephone base. Plug the power adapter into a different, working electrical outlet without a wall switch.
- Move the cordless handset closer to the telephone base. You may have moved out of range.
- Reset the telephone base. Unplug the electrical power. Remove the handset battery. Wait for 15 seconds then plug the power cord back in. Allow up to one minute for the cordless handset and telephone base to reset.
- Other electronic products can cause interference with your cordless phone. Try installing your phone as far away as possible from these types of electronic devices.

Out of range or No power at base appears on my cordless handset.

- Ensure you plug the telephone base in properly and the power is on.
- Place the cordless handset closer to the telephone base for synchronization.

- Move the cordless handset closer to the telephone base. You may have moved out of range.
- Reset the telephone base. Unplug the electrical power. Wait for 15 seconds then plug it back in. Allow up to one minute for the cordless handset and telephone base to reset.
- Other electronic products can cause interference with your cordless phone. Try installing your phone as far away as possible from these types of electronic devices.

The handset battery does not accept charge.

- If the cordless handset is in the telephone base or charger and the charge light is not on, refer to **The charge light is off** on page 80.
- Charge the battery in the cordless handset for at least 11 hours. For optimum daily performance, return the cordless handset to the telephone base or charger when not in use.
- If the battery is completely depleted, charge the handset for at least 30 minutes before use.
- You may need to purchase a new battery.

There is no chime from the doorbell when it is pressed.

- Make sure you install two AA batteries and connect domestic power supply to the doorbell.
- The doorbell light on the doorbell flashes when the doorbell is pressed. If the light doesn't flash, the doorbell may have run out of battery. You may need to replace new batteries.
- Make sure the doorbell is registered to the telephone system.

The handset receives no signal of video streaming when the doorbell is pressed.

- Make sure you install two AA batteries and connect domestic power supply to the doorbell.
- Make sure the doorbell is registered to the telephone system.
- Make sure your handset is in reception range and works probably.

- Make sure the chime volume of your handset is not set to off. Refer to **Chime volume** on page 54 in this user's manual.
- If there is an incoming call when the doorbell is pressed, the handset will not respond to the chime.
- When three or more system handsets are in use for a call at a time, video streaming will be disabled.
- If the previous suggestions do not work, deregister all devices and register them to the telephone base again.

The captured image or video streaming is too bright or too dark.

- If the image is too bright, it may be caused by sunlight reflection. Avoid mounting the doorbell to where it is exposed to direct sunlight or reflections caused by sunlight.
- If the image is too dark, make sure the location where the doorbell is installed has enough exposure to light. If you would like to use the built-in infrared feature for enhanced brightness, make sure the surroundings is dark enough for this feature to be used.
- During video streaming, press **ISO** followed by **+** or **-** to adjust the brightness level.
- If the previous suggestions do not work, find another location to install the doorbell. Refer to **Locating the doorbell** on pages 16-20 in this user's manual.

I can hear only audio but see no video when I try to perform the video streaming.

- When two handsets in the telephone system are in use for a call, you can only perform audio streaming with the doorbell using other handset(s). To allow video streaming to take place, end the call on either handset or both handsets.

When the handset chimes and I try to answer, it shows Not available at this time.

- Make sure no handset is using intercom.

I get noise, static, or weak signals even when I'm near the telephone base.

- If you subscribe to high-speed Internet service (DSL - digital subscriber line) through your telephone line, you must install a DSL filter between the telephone line cord and the telephone wall jack. The filter prevents noise and Calling Number Display problems as a result of DSL interference. Contact your DSL service provider for more information about DSL filters.
- You may be able to improve the performance of your cordless phone by installing your new telephone base as far as possible from any other existing cordless telephone system that may already be installed.
- Other electronic products can cause interference with your cordless phone. Try installing your phone as far away as possible from these types of electronic devices.
- Do not install this phone near a microwave oven or on the same electrical outlet. You may experience decreased performance while the microwave oven is operating.
- If you plug your phone in with a modem or a surge protector, plug the phone (or modem/surge protector) into a different location. If this does not solve the problem, relocate your phone or modem farther apart from one another, or use a different surge protector.
- Relocate your phone to a higher location. The phone may have better reception in a high area.
- If other phones in your home are having the same problem, contact your telephone service provider (charges may apply).

I experience poor sound quality when using the handset speakerphone.

- For increased sound quality while using the handset speakerphone, place the handset on a flat surface with the dialing keys facing up.

I hear other calls while using my phone.

- Disconnect the telephone base from the telephone jack, and plug in a different telephone. If you still hear other calls, call your telephone service provider.

The telephone does not ring when there is an incoming call.

- Make sure that the ringer is not off.
- Make sure you plug in the telephone line cord securely into the telephone base and the telephone jack. Make sure you plug in the power cord securely.
- The cordless handset may be too far from the telephone base.
- Charge the battery in the cordless handset for at least 11 hours. For optimum daily performance, return the cordless handset to the telephone base or charger when not in use.
- You may have too many extension phones on your telephone line to allow all of them to ring simultaneously. Try unplugging some of the other phones.
- The layout of your home might be limiting the operating range. Try moving the telephone base to another location, preferably to a higher location.
- If other phones in your home are having the same problem, contact your telephone service provider (charges may apply).
- Test a working phone at the phone jack. If another phone has the same problem, contact your telephone service provider (charges may apply).
- Other electronic products can cause interference with your cordless phone. Try installing your phone as far away as possible from these types of electronic devices.
- Remove and install the cordless handset battery again. Place the cordless handset in the telephone base or charger. Wait for the cordless handset to reestablish its connection with the telephone base. Allow up to one minute for this to take place.
- Your line cord may be defective. Try installing a new line cord.

My calls cut in and out while I'm using my cordless handset.

- Other electronic products can cause interference with your cordless phone. Try installing your phone as far away as possible from these types of electronic devices.

- Do not install this phone near a microwave oven or on the same electrical outlet. You may experience decreased performance while the microwave oven is operating.
- If you plug your phone in with a modem or surge protector, plug the phone (or modem/surge protector) into a different location. If this does not solve the problem, relocate your phone or modem farther apart from one another, or use a different surge protector.
- Relocate your telephone base to a higher location. The phone may have better reception when installed in a high area.
- If other phones in your home are having the same problem, contact your telephone service provider (charges may apply).

The charge light is off.

- Make sure you plug the power and line cords in correctly and securely.
- Reset the telephone base. Unplug the electrical power. Remove the handset battery. Wait for 15 seconds then plug the power cord back in. Allow up to one minute for the cordless handset and telephone base to reset.
- Clean the charging contacts on the cordless handset and the telephone base or charger each month with a pencil eraser or cloth.
- Make sure that the handset battery is installed properly.

My Calling Number Display isn't working properly.

- Calling Number Display is a subscription service. You must subscribe to this service from your telephone service provider for this feature to work on your phone.
- The caller must be calling from an area that supports Calling Number display.
- Both your and your caller's telephone service providers must use Calling Number Display compatible equipment.

- If you subscribe to high-speed Internet service (DSL - digital subscriber line) through your telephone line, you must install a DSL filter between the telephone line cord and the telephone wall jack. The filter prevents noise and Calling Number Display problems resulting from DSL interference. Contact your DSL service provider for more information about DSL filters.

My telephone does not receive Calling Number Display when on a call.

- Make sure you subscribe to Calling Number Display with call waiting features from your telephone service provider. Calling Number Display feature works only if both you and the caller are in areas offering Calling Number Display service, and if both telephone service providers use compatible equipment.

The messages on the answering machine are incomplete.

- If a caller leaves a very long message, part of it may be lost when the answering machine disconnects the call after the preset recording time.
- If the caller pauses for too long, the answering machine stops recording and disconnects the call.
- If memory on the answering machine becomes full during a message, the answering machine stops recording and disconnects the call.
- If the caller's voice is very soft, the answering machine may stop recording and disconnect the call.

The messages are very difficult to hear.

- Press **VOL+** on the telephone base, or press **VOL+** on the cordless handset to increase the listening volume.

The answering machine does not answer after the correct number of rings.

- Make sure that the answering machine is on. **ANS ON** should show on the cordless handset and **🔊/ANS ON/OFF** light on the telephone base should be on.
- If toll saver is activated, the number of rings changes to two when you have new messages stored.
- If the memory is full or the machine is off, the machine will answer after 14 rings.

- In some cases, the answering machine is affected by the ringing system used by your telephone service provider.
- If you subscribe to voicemail service, change the number of rings so that your answering machine answers before your voicemail answers. To determine how many rings activate your voicemail, contact your telephone service provider.
- If there is a fax machine connected to the same telephone line, try disconnecting the fax machine. If that solves the problem, consult your fax machine documentation for information on compatibility with answering machines.

The telephone does not respond to remote commands.

- Make sure you enter your remote access code correctly.
- Make sure you are calling from a touch-tone phone. When you dial a number, you should hear tones. If you hear clicks, the phone is not a touch-tone telephone and cannot activate the answering machine.
- The answering machine may not detect the remote access code while your announcement is playing. Try waiting until the announcement is over before entering the code.
- There may be interference on the phone line you are using. Press dialing keys firmly.

The answering machine does not record messages.

- Make sure that the answering machine is on. **ANS ON** should show on the cordless handset and **🔌/ANS ON/OFF** light on the telephone base should be on.
- Make sure the memory of the answering machine is not full.
- If you subscribe to voicemail service, change the number of rings so that your answering machine answers before your voicemail answers. To determine how many rings activate your voicemail, contact your telephone service provider.
- If there is a fax machine connected to the same telephone line, try disconnecting the fax machine. If that solves the problem, consult your fax machine documentation for information on compatibility with answering machines.

The answering machine announces “Time and day not set.”

- You need to reset the system clock.

The outgoing announcement is not clear.

- When you record your announcement, make sure you speak in a normal tone of voice, about 20 centimeters from the handset or telephone base.
- Make sure there is no background noise (TV, music, etc.) while recording.

New voicemail and show and I don't know why.

- Your telephone has both a built-in answering machine and voicemail indication. If New voicemail and  appear, then your telephone has received a signal from your telephone service provider that you have a voicemail message waiting for you to retrieve from them. Contact your telephone service provider for more information on how to access your voicemail.

I cannot retrieve voicemail messages.

- Your telephone has both a built-in answering machine and voicemail indication. They are independent features and each alerts you to new messages differently. If you subscribe to voicemail service from your telephone service provider, contact your telephone service provider for more information on how to access your voicemail.

Common cure for electronic equipment:

If the telephone is not responding normally, try resetting the telephone. Do the following in the order listed:

1. Disconnect the power to the telephone base.
2. Disconnect the cordless handset battery.
3. Wait a few minutes.
4. Connect power to the telephone base.
5. Re-install the cordless handset battery and place the handset into the telephone base or charger.
6. Wait for the handset to reestablish its connection with the telephone base. Allow up to one minute for this to take place.

TecHelp line 1300 369 193

Call TechHelp:

- if you are having difficulties using your Telstra 13950.
- if you need a replacement battery or mains power lead.

GENERAL INFORMATION

REPLACING THE HANDSET BATTERY

After a time, you may find that the handset battery is running out of charge more quickly.

This is a standard sign of wear and the battery will need replacing. Replacement rechargeable Nickel Metal Hydride (NiMH) batteries can be purchased from TechHelp line on 1300 369 193 your local electrical retailer. Slide off the battery compartment cover and remove existing battery. Insert the new battery and replace the compartment cover until it clicks into place.

SAFETY

- Only use the power supply included with the product. Using an unauthorised power supply will invalidate your guarantee and may damage the telephone.
- Use only the approved rechargeable battery supplied. Spare rechargeable batteries can be purchased from TechHelp on 1300 369 193 or your local electrical retailer.
- Do not open the handset (except to replace the handset battery) or the base. This could expose you to high voltages or other risks.
- Radio signal transmitted between the handset and base may cause interference to hearing aids.
- It is recommended that advice from a qualified expert be sought before using this product in the vicinity of emergency / intensive care medical equipment.
- Your product may interfere with other electrical equipment, e.g. TV and radio sets clock / alarms and computers if placed too close. It is recommended that you place your product at least one metre away from such appliances to minimise any risk of interference.
- Disconnect telephone line from base when replacing back-up batteries.

Please note

Telstra accepts no responsibility for damage caused to your Telstra 13950 handset by using any other type of battery.

- Never dispose of batteries in a fire. There is a serious risk of explosion and/or the release of highly toxic chemicals.
- Dispose of batteries as per local / state requirements.

CLEANING

Simply clean the handset and base with a damp (not wet) cloth, or an anti-static wipe.

Never use household polish as this will damage the product. Never use a dry cloth as this may cause a static shock.

ENVIRONMENTAL

- Do not expose to direct sunlight.
- The product may heat up when the battery is being recharged or during prolonged periods of use. This is normal. However, we recommend that to avoid damage you do not place the product on antique / veneered wood.
- Do not stand your product on carpets or other surfaces which generate fibres, or place it in locations preventing the free flow of air over its surface.
- Do not submerge any part of your product in water and do not use it in damp or humid conditions, such as bathrooms.
- Do not expose your product to fire, explosive or other hazardous conditions.
- There is a slight chance that your phone could be damaged by an electrical storm. We recommend that you unplug the power and telephone line cord from the base for the duration of the storm.

HOW MANY TELEPHONES CAN YOU HAVE?

All items of telephone equipment have a Ringer Equivalence Number (REN), which is used to calculate the number of items which may be connected to any other telephone line. Your Telstra 13950 has a REN of 1.0. A total REN of 3 is allowed, if the total REN of 3 is exceeded, the telephone may not ring. With different telephone types there is not guaranteed of ringing, even when the REN is less than 3.

CUSTOMER SERVICE & PRODUCT WARRANTY

IMPORTANT

Please retain this booklet with your sales receipt as proof of the date of purchase.

Customer Service

If you require assistance in operating this product please call the TechHelp Information Line on 1300 369 193 or contact VTech by e-mail at: tcpsupport_au@vtech.com.

If you are trying to access a Telstra Network Service and require assistance specifically related to the network service or would like to subscribe to the service, contact Telstra on 13 22 00 for residential or 13 20 00 for business.

Voluntary Product Warranty

In addition to your Statutory Rights and subject to the conditions below, VTech warrants that this product will be free from any defect in materials or workmanship under conditions of normal use for a period of 12 months from date of purchase.

VTech do not warrant that the product will be free from defects if defects are caused by an accident, misuse, abuse, improper installation or operation, vermin infestations, lack of reasonable care, unauthorised modification, loss of parts, tampering or attempted repair by a person not authorised by VTech; or where the product has been damaged by lightning or a mains power surge.

Where a valid claim is made under this Voluntary Product Warranty, VTech will, at no cost to you, repair or replace the product within a reasonable time. Subject to your Statutory Rights, if your claim under this Voluntary Product Warranty is not valid, you may be charged a fee under this Voluntary Product Warranty for the service and for any direct costs associated with having the product delivered for service.

To make a claim under this Voluntary Product Warranty you must call the TechHelp Information Line on 1300 369 193 or contact VTech by e-mail at: tcpsupport_au@vtech.com where a Customer Service Representative will inform you of the product return process. You will need to ensure that:

You provide proof of purchase;

Your product is suitably packaged (original packaging is not required); and

You have included all components from the original purchase.

For your records

Date of purchase:

Place of purchase:

Serial number:

For Voluntary Product Warranty purposes proof of purchase is required so please keep your receipt.

The benefits conferred by this Voluntary Product Warranty are in addition to other rights and remedies that are available to you under law, which cannot be excluded. The processes for this Voluntary Product Warranty in no way limit your rights which arise as a result of your Statutory Rights.

This Voluntary Product Warranty is given by:

VTech Telecommunications (Australia) Pty Ltd ABN 70 136 672 627

Address: 24 Gilby Road, Mount Waverley 3149

IMPORTANT NOTE: THIS IS NOT A PRODUCT RETURN OR SERVICE ADDRESS – PLEASE CONTACT TECHHELP BY PHONE OR EMAIL FOR PRODUCT AND WARRANTY SUPPORT. NO LIABILITY WILL BE ACCEPTED BY VTECH FOR PRODUCTS RETURNED TO THIS ADDRESS UNDER THIS VOLUNTARY PRODUCT WARRANTY.

Phone number: 1300 369 193

Email address: tcpsupport_au@vtech.com

Statutory Rights

Our goods come with guarantees that cannot be excluded under the Australian Consumer Law. You are entitled to a replacement or refund for a major failure and compensation for any other reasonably foreseeable loss or damage. You are also entitled to have the goods repaired or replaced if the goods fail to be of acceptable quality and the failure does not amount to a major failure.

FOR MORE INFORMATION CALL:
TECHELP ON 1300 369 193 OR
EMAIL: TCPSUPPORT_AU@VTECH.COM

Version A
91-007323-010-100