

# Getting to know your Telstra Easy Control Desktop Phone

Model TEC-D



## 2 Check box contents

---



TEC-D corded  
telephone with handset

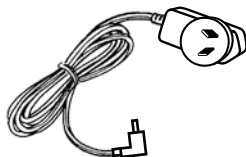

Mains power adaptor

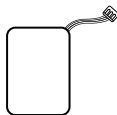

Battery pack



Telephone line cord



### Important

Only use the mains power adaptor and cables that came with your TEC-D. Telstra accepts no responsibility for damage caused to your TEC-D if you use any other cables.

Menu map .....4

Quick set-up guide .....5

## Getting to know your phone

Finding your way around  
your phone .....9

Handset buttons .....10

## Using the phone

Making calls .....11

Mute .....11

Handsfree .....12

Viewing the Calls list .....14

Time and date .....15

Help .....16

Wall mounting .....17

General information .....18

## 4 Menu map

---

### Time & date

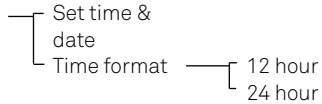

### Calling Features

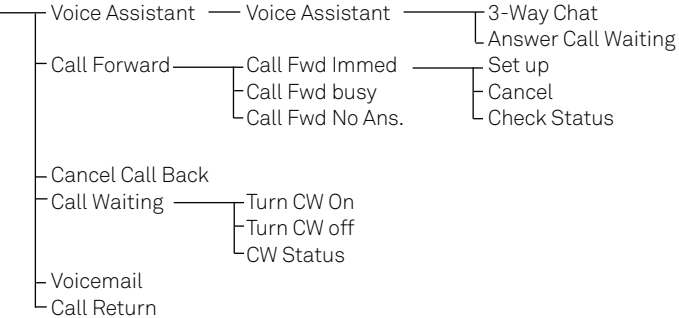

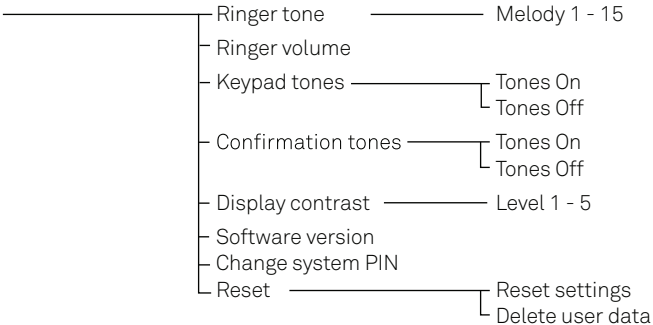

### Settings

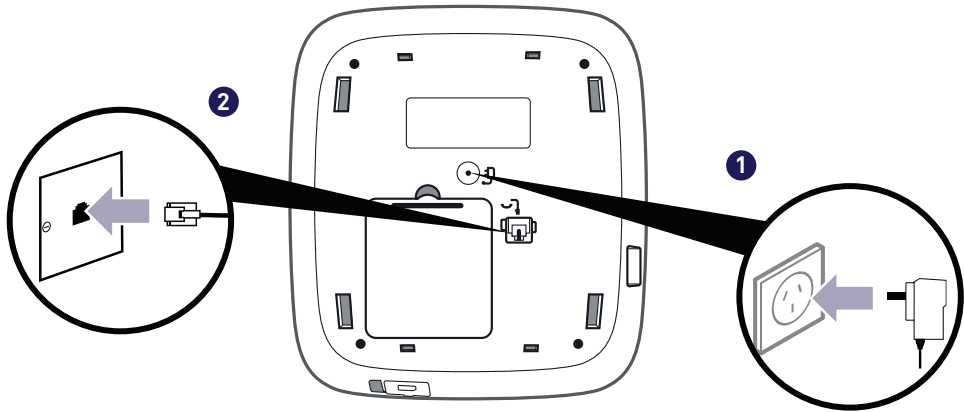

## 5 Quick set-up guide

### 1 Plug in



1. First, plug the mains power adaptor into the base in the socket marked .
2. Plug the other end of the power adaptor into the wall power socket and switch socket on.
3. Plug the telephone line cord into the base in the socket marked  Line. Plug the other end of the cable into the phone wall socket.
4. LCD display will light up.

## 6 Quick set-up guide

### 2 Follow the set up wizard

1. The set-up wizard will then begin. Follow the prompts to finish set-up. To select OK, press the left option button  below the display.

#### Set the time and date

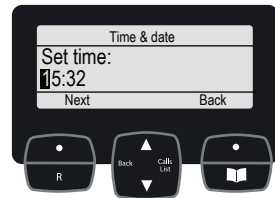
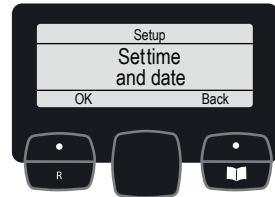

2. Use the keypad to enter the time. The default time format setting is 24 hours, but you can change this to 12 hours under Time format in the Time & Date menu.
3. Press **Next**, then enter the date, in the format **DD/MM/YYYY**.
4. Press  to **Save**.



## 7 Quick set-up guide

---

### Adding contacts

8. Select **Yes** to add contacts now (or press the right option button  to skip to the next step).
9. Use the number buttons on the keypad to enter the name of a new contact. To select the correct letter, press the number button it appears on e.g. for Emma, press  twice and do the same thing to complete the rest of the name.
10. When you've finished the name you want to save, press **Next**.  
**Tip:** if you make a mistake, go back a digit by selecting **Clear**, .
11. Then use the keypad to enter the telephone number and press **Save**.
12. To add another, select **Yes** and then repeat steps 9 to 11.

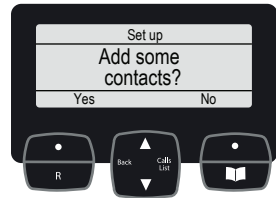

13. If you don't want to add more contacts now, select **No** to finish the set-up wizard. You can now start using your phone. To find out how to use the most popular features of your TEC-D, please read the rest of this quick user guide.









## 9 Getting to know your phone



---

### Finding your way around your phone

The TEC-D has an easy to use menu.

When the display shows the idle screen:

1. Press the left option button  to open the Menu.
2. Use  or  to scroll through the menu options.
3. When the menu you want is displayed, select by pressing the left option button .

Use  or  to scroll through the available sub menu options.

When the sub menu you want is highlighted, press **OK** .

Select the **Back** option , if you want to return to the previous screen.

To exit a menu and return to the home screen, press .

If no buttons are pressed for one minute, the display returns to the idle screen automatically.

## Handset buttons

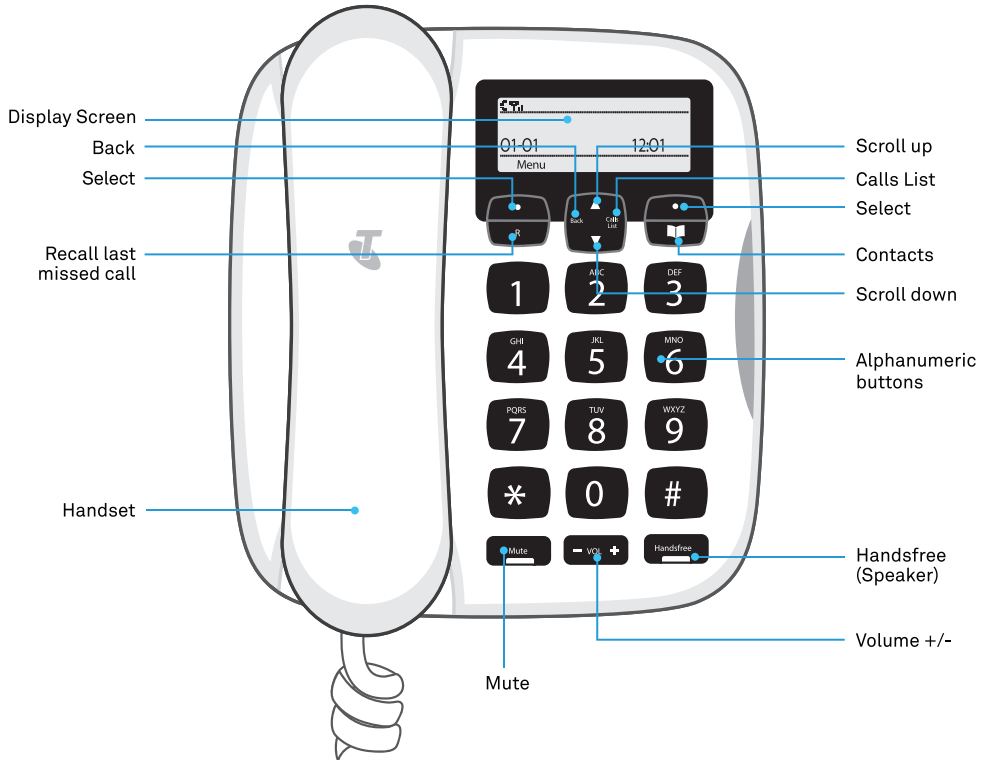

## 11 Using the phone

---

### Making calls

#### Make an external call

To make a call, just lift the handset and dial the number you wish to contact.



To end the call, replace the handset.

#### Receive a call

When you receive a call, the phone rings and the display shows **Incoming call**. If you've got a caller display service, the display shows the incoming call, caller's number (if available) or the caller's name.

1. Lift the receiver to answer the call. To use Handsfree, press . A green light will show when it's switched on.

#### Mute

1. During a call, select **Mute** by pressing . The red light on the button will show. If the light is on, the call is **muted** and your caller can't hear you.
2. Press the  button again to return to your caller.



#### Incoming speech / Handsfree volume

1. Press  to increase or decrease the volume. Subsequent presses will change the volume, you will hear the volume level with each press.



From the idle screen, you can press to change the ringer volume settings too.

### Make a Handsfree call

1. Enter the number you wish to call.
2. Then press the  to connect.
3. To end the call, press the  again.

### Contacts

#### Store a contact (up to 200)

1. From the idle screen, press .
2. Press **Options**. **Add new contact** is highlighted, press **OK**.
3. Enter the new contact name using the keypad then press **Next**. Enter the phone number and select **Save** when you've finished. The display will show **Contact saved**.



You can add up to 14 characters for contact names and 24 digits for their telephone number.



## 13 Using the phone

---

### Character map

1	& . , ' ? ! @ 1
2	a b c 2
3	d e f 3
4	g h i 4
5	j k l 5
6	m n o 6
7	p q r s 7
8	t u v 8
9	w x y z 9
0	space 0
*	*
#	Changes text entry mode (sentence case, upper, lower or numeric)



### View/dial a contact

1. From the idle screen, with the handset down, press  to open your contact list.
2. Press  and  to scroll through and view the entries.
3. When you have found the contact you wish to call, lift the handset to connect the call.



## The Calls list

To get the most out of the features on your new phone, you should subscribe to a Caller Display service. Your network provider may charge you for this service.

### View and dial from the Calls list

1. With the handset down, press . The most recent entry is at the top of the list. (If there are no entries **Calls list empty** will be displayed)
2. Press  or  to scroll through and view the list.
3. To dial, lift the handset when the entry you want is highlighted.

### Save a Calls list entry to your contacts

1. Press , then press  and  to highlight the entry you want to save and select **Options**.
2. **Save number** is displayed, press **OK**.
3. Enter the name of the new contact and press **Next**.
4. The number you wish to save is displayed. Press **Save** to add as a contact.





## 15 Using the phone

---

### Time and date

#### Choose a time format

You can use a 24 hour or 12 hour format to display the time on your phone. To set your preference:

1. Select **Menu**, scroll through to **Time & Date** and press **OK**.
2. Use the  and  to scroll to **Time format**, then use the  or  buttons to highlight the format you want to use and press **OK**.

#### Set the time and date

1. Select **Menu**, scroll to display **Time & Date** and press **OK**.
2. Scroll through to **Set time & date**, then press **OK**.
3. Enter the digits for the time and press **Next**. Then enter the digits for the date and press **Save**.

## Phone doesn't work

- Check that the mains power is correctly connected.

## No dial tone or line cord error message displayed on screen

- Is the telephone cord plugged into the base and phone wall socket?
- Check that the mains power is correctly connected.
- Only use the telephone cord supplied with the phone.

## Can't make or receive calls

- Check that the mains power is correctly connected.
- Check that product call barring is not active.
- Has there been a power cut? If so, the screen will show the **Power Cut? Set time ?** message. Reset the time and date and check that you can now hear the dialling tone.

## You have a dial tone, but the phone won't dial out

- If you're connected to a switchboard, check whether you need to dial an access code, go to <https://go.telstra.com.au/helpandsupport/home-phone/>.



You will still be able to make and receive calls if the power fails. The phone comes with a back-up battery which gives you up to 8 hours of stand-by time.



## 17 Wall mounting

**Your phone will come ready to be placed on a table, but converts easily for wall mounting as follows:**

1. Turn the phone so that base faces up (notches point downward).
2. Remove the detachable base bracket.
3. Rotate base bracket 180 degrees, so that wedge is now at the base of phone. Place it back onto the phone unit and click in place (notches point upward).
4. Change hook switch position for hanging up the handset. Use finger pad to push down the base of hook switch to flip it into reverse position (with hollows facing up).
5. Hang handset onto phone unit so that it clicks into the hook switch hollow to hold it firm.
6. Keep the phone and power cables tidy by running them through the provided space.

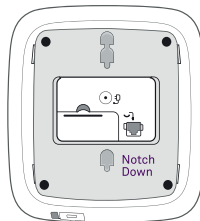

Desk mount position

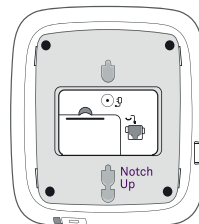

Wall mount position



Hook switch for desk mount

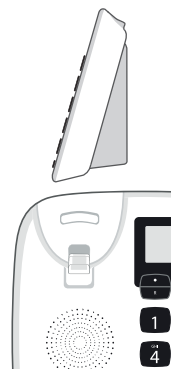

Hook switch for wall mount

## Guarantee

Our goods come with guarantees that cannot be excluded under the Australian Consumer Law. You are entitled to a replacement or refund for a major failure and compensation for any other reasonably foreseeable loss or damage. You are also entitled to have the goods repaired or replaced if the goods fail to be of acceptable quality and the failure does not amount to a major failure.

To find out more information about your consumer rights if your device is faulty, please call us on 13 2200 or go to <https://go.telstra.com.au/helpandsupport/home-phone/> or <http://www.telstra.com/faultyproducts>

## How to recycle your equipment

When the TEC-D reaches its end of life, it needs to be disposed of according to local laws and regulations, please contact the customer service helpline found in this user guide for information on how to dispose of the product free of charge.

## Important safety instructions

Follow these safety precautions when using your phone to reduce the risk of fire, electric shock, and injury to persons or property:

Keep all slits and openings of the phone unblocked. Do not set the phone on a heating register or over a radiator.

Ensure that proper ventilation is provided at the installation site.

Do not use while wet or while standing in water.

Do not use this product near water (for example, near a bath tub, kitchen sink, or swimming pool).

Do not allow anything to rest on the power cord. Place the power cord so that it will not be walked on.

Never insert objects of any kind into the product vents as that may result in fire or electric shock.

Unplug this product from the wall outlet before cleaning.

Do not use liquid cleaners or aerosol cleaners. Use a damp cloth for cleaning.

## 19 General information

---

Do not disassemble this product. If service or repair work is required, contact the customer service helpline found in this user guide.

Do not overload wall outlets and extension cords.

Avoid using during an electrical storm. Use a surge protector to protect the equipment.

Do not use this phone to report a gas leak, especially if you are in the vicinity of the gas line.

Small metal objects may stick to the handset due to the presence of magnetic fields on the handset. Exercise caution when used where metal objects can be picked up.

### **Cleaning**

Clean the handset and base (or charger) with a damp (not wet) cloth, or an anti-static wipe. Never use household polish as this will damage the product. Never use a dry cloth as this may cause static shock.

### **Technical Information**

How many telephones can I have?

All items of telephone equipment have a Ringer Equivalence Number (REN), which is used to calculate the number of items which may be connected to any one telephone line. Your TCG302 has a REN of 0,2. A total REN of 3 is allowed. If the total REN of 3 is exceeded, the telephones may not ring. With different telephone types, there is no guarantee of ringing, even when the REN is less than 3.





[telstra.com/fix](https://telstra.com/fix)



[crowdsupport.telstra.com.au](https://crowdsupport.telstra.com.au)



13 22 00