

Hosting and Internet
Protocols and Signalling

Technical Reference
RCIT.0006

**Customer End Splitter Information for
ADSL/POTS Spectrum Sharing**
DRAFT

Implementation:

Uncontrolled Document - No Unauthorised Copying

TABLE OF CONTENTS

1. ...PURPOSE.....	3
2. ...SCOPE.....	3
3. ...PRODUCT DESCRIPTION.....	3
4. ...PERFORMANCE OBJECTIVES	5
4.1. Customer End Splitter	5
4.1.1. General	5
4.1.2. Inline Filters	5
4.1.3. Centralized Filters	5
4.1.4. V.90 Modem performance	6
5. ...DEFINITIONS.....	6
6. ...REFERENCES	7
7. ...DOCUMENT CONTROL SHEET	8

1. PURPOSE

The purpose of this Technical Reference is to provide the requirements for installation of ADSL Splitters located at customer premises end of a loop with spectrum sharing between ADSL and POTS. The requirements are considered necessary to allow satisfactory operation of voiceband CPE currently in use.

2. SCOPE

This Technical Reference gives the limits for the number of in line splitters and the limits for the number of Customer Equipment (CE) for customer premises ends of a loop with spectrum sharing between ADSL and POTS.

This Technical Reference does not contain the splitter specification, this is contained in Technical Reference RCIT.0004 "Splitter Specification for ADSL/POTS Spectrum Sharing"

3. PRODUCT DESCRIPTION

The Telstra Wholesale Spectrum Sharing Service (SSS) product allows an Acquirer to use vacant frequency spectrum, at frequencies above an existing voiceband PSTN service provided by Telstra. Spectrum Sharing will be provided on an unconditioned communications pair between the boundary of a telecommunications network at an end-user's premises and a point on a telecommunications network that is a potential point of interconnection located at, or associated with, an Acquirer's customer access module (CAM) and located on the end-user side of the customer access module.

Spectrum Sharing will be provided over a single existing twisted metallic pair. Acquirers will need to provide their own DSLAMs, compliant ADSL modems and compliant filters that are suitable for connection to the Telstra network. Acquires will also be required to install a Network Termination Device (NTD) at the end-customer premises when applicable. Spectrum Sharing will be available nationally subject to the Acquirer having rolled out their equipment.

Spectrum Sharing will be subject to the availability of suitable twisted metallic pairs, distance restrictions, Service Qualification requirements and deployment guidelines as identified by the appropriate ACIF Code for the delivery of ADSL services.

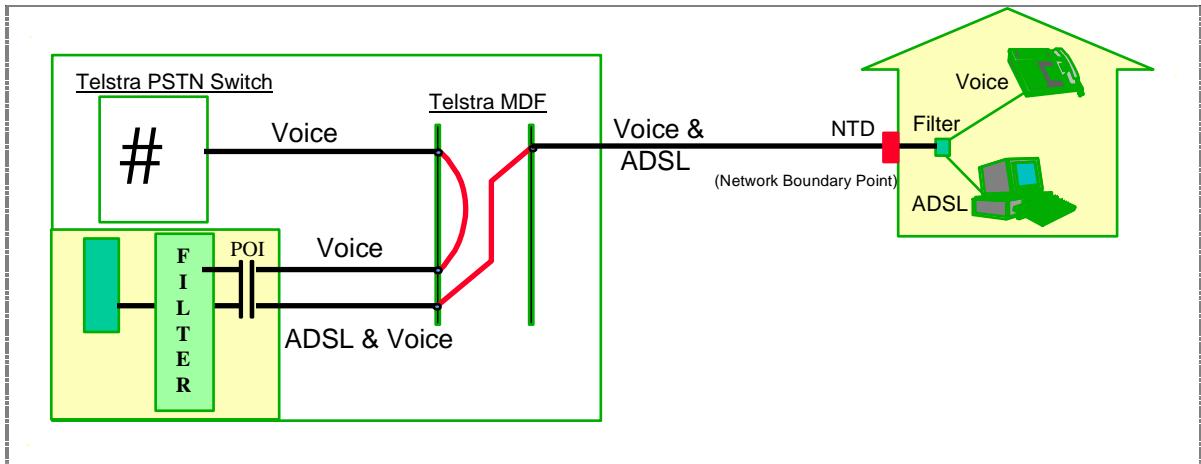

Figure 1: - Telstra Wholesale Spectrum Sharing Service (end-to-end view)

4. PERFORMANCE OBJECTIVES

4.1. CUSTOMER END SPLITTER

4.1.1. General

The customer end splitter may be implemented as a centralised or an in line (distributed) splitter beyond the NTD. New customer premises cabling is to be provided from the centralised splitter to the ADSL CPE. The splitter provides a low pass filtering functionality in the telephony path. The high pass component of the splitter is assumed to be in the ADSL CPE.

Telstra only supports 3 REN (Ringer Equivalence Number) on a standard telephone service. For example the Telstra standard telephone has a REN of 1.0, therefore only 3 standard telephones can be supported on a standard telephone service. Some CE may have a REN less than 1, meaning that more than 3 CE can be supported on the one service. Where REN is not stated on the POTS terminal, contact the supplier to obtain the REN value.

Because of its superior performance over the inline type it is very strongly recommended that the customer end splitter be of the centralised type.

The Acquirer must ensure that any filter complies with the requirements of ETSI TR 101.728 V1.2.1 (2002-05) and ETSI TS 101 952-1-1 V1.1.1 (2002-05) as modified for the Australian environment in Telstra specification RCIT 0004 “Splitter Specification for ADSL/POTS Spectrum Sharing” .

4.1.2. Inline Filters

Where distributed (inline) splitters are used, no more than 3 inline filters may be used on any POTS service.

If more than 3 POTS terminals are to be connected (or if any is a wallphone without RJ12 socket) then a centralised splitter is required.

4.1.3. Centralised Filters

Customers must not connect more than 3 standard Telstra telephones or equivalent on the centralised splitter used for ADSL. However more equipment can be connected if the total REN does not exceed 3.

Should any more than 3 standard Telstra telephones or equivalent be used, Telstra will not be responsible for any degradation of the service. This includes loss of incoming calls and impaired voice and data quality.

Where a centralised splitter is used it may be provided with a Network Termination Device located between the lead-in and the first telephone socket in the premises (or on the network side of any block from which telephone sockets are star wired). For Information on Network Termination Device please see:

Telstra Network Termination Device, Information for Cabling Providers.
Guideline 012 688

4.1.4. V.90 Modem performance

The performance of V.90 Modems may be adversely affected if more than 3 inline filters are used.

5. DEFINITIONS

The following words, acronyms and abbreviations are referred to in this document.

<u>Term</u>	<u>Definition</u>
ACA	Australian Communications Authority
ACCC	Australian Competition and Consumer Commission
Acquirer	The service provider seeking to utilise Telstra Wholesale Spectrum Sharing Service on behalf of their retail customer.
AP	Access Provider
ADSL	Asymmetric Digital Subscriber Line
BEP	Building Entry Point
CAM	Customer Access Module
CCF	Cross Connect Facility
CE	Customer Equipment
CPE	Customer Premises Equipment
ECP	Equipment Connection Point
IDF	Intermediate Distribution Frame
MDF	Main Distribution Frame
NBP	Network Boundary Point
NTD	Network Termination Device
PSTN	Public Switched Telephone Network
PSD	Power Spectral Density
REN	Ringer Equivalence Number
SDP	Service Delivery Point
ULLS	Unconditioned Local Loop Service

6. REFERENCES

Document Number	Title
Technical Reference RCIT.0004	Splitter Specification for ADSL/POTS Spectrum Sharing, Draft
Guideline 012688	"Telstra Network Termination Device, Information for Cabling Providers"
ETSI TR 101.728 V1.1.1 (2002-5)	Access and Terminals (AT); Study for the Specification of the Low-Pass Section of POTS/ADSL Splitters
AS/ACIF S002: December 2001	Analogue interworking and non-interference requirements for Customer Equipment for connection to the Public Switched Telephone Network
AS/ACIF S043 - PART 1	Requirements for Customer Equipment for connection to a metallic local loop interface of a Telecommunications Network - Part 1: General
AS/ACIF S043 - PART 2	Requirements for Customer Equipment for connection to a metallic local loop interface of a Telecommunications Network - Part 2: Digital Subscriber Line (DSL)
AS/ACIF S043 - PART 3	Requirements for Customer Equipment for connection to a metallic local loop interface of a Telecommunications Network - Part 3: DC, low frequency AC and voiceband
DR/ACIF C559	INDUSTRY CODE UNCONDITIONED LOCAL LOOP SERVICE Network Deployment Rules
DR/ACIF C569	INDUSTRY CODE UNCONDITIONED LOCAL LOOP SERVICE Ordering, Provisioning and Customer Transfer
ACIF G572	INDUSTRY CODE UNCONDITIONED LOCAL LOOP SERVICE Fault Management
AS/NZS 60950:2000	Safety of information technology equipment (IEC 60950:1999, MOD)
AS/NZS 3548:1995	Limits and methods of measurement of radio disturbance characteristics of information technology equipment (IEC/CISPR 22:1993)

7. DOCUMENT CONTROL SHEET

Contact for Enquiries and Proposed Changes

If you have any questions regarding this document contact:

Name: Warwick O'Connor
 Designation: P3, Integration Specialist
 Phone: (03) 9634 7152
 Fax: (03) 9634 8658

If you have a suggestion for improving this document, complete and forward a copy of *Suggestions for Improvements to Documentation* (form 000 001-F01).

Issue No	Issue Date	Nature of Amendment
Issue 1.0	26/4/02	Document updated to include Merv Sewell's comments.
2	31/05/02	Minor corrections after internal review.

Intellectual Property Rights

Equipment which is manufactured to comply with this specification may require the use of technology which is protected by patent rights in Australia. Questions about the availability of such technology, under license or otherwise, should be directed to the patent holder or Australian licensee (if known) or through enquiry at the Australian Industrial Property Organisation which incorporates the Patent, Trade Marks and Designs Office in each State.

This publication has been prepared and written by Telstra Corporation Limited (ACN 051 775 556), and is copyright. Other than for the purposes of and subject to the conditions prescribed under the Copyright Act, no part of it may in any form or by any means (electronic, mechanical, microcopying, photocopying, recording or otherwise) be reproduced, stored in a retrieval system or transmitted without prior written permission from the document controller. Product or company names are trademarks or registered trademarks of their respective holders.

Note for non-Telstra readers: The contents of this publication are subject to change without notice. All efforts have been made to ensure the accuracy of this publication. Notwithstanding, Telstra Corporation Limited does not assume responsibility for any errors nor for any consequences arising from any errors in this publication.